

The Stancor Oil-Minder® Control and Pump System is designed and approved for safe operation of pumping, alarming and monitoring of elevator sump pits, transformer vaults and other applications where oil and water must be detected. The Stancor Oil-Minder® system will activate the pump to remove water from elevator pits in accordance with ASME A17.1, and will provide pumping of water only, even if an oil condition is detected. The Stancor Oil-Minder® cycles the pump only in the water range. Oil and other harmful substances are not discharged into the environment. An alarm is activated in the event of a high water condition or high oil condition.

**Oil-Minder® Description of Operation**

As the liquid level rises in the sump, the pump ON float starts the pump provided the sensor probe detects water. The pump runs until the liquid level drops and the probe no longer senses water. Any oil layer will not be pumped out of the sump. If the liquid (oil or water) level rises in the sump and reaches the high alarm float, an alarm is activated. If the sensor detects oil, the pump will stop and the oil will be contained.

**Features:**

- NEMA 4x weathertight corrosion resistant polycarbonate enclosures
- Stainless Steel sensor probe with patented electronic technology that repels dirt contamination.
- Single direct plug-in power source for operation of entire system.
- Solid state components.
- Alarms, lights, silence switch, and remote monitoring circuit for oil, high liquid, and high amperage conditions as well as many custom options are available.
- Complete factory assembly and testing insures quality of entire pump and control system.
- Patented - Pat. #4,715,785, #4,752,188, #6,203,281 and others pending.
- Oil-Minder® System can be combined with a variety of different pumps and valves.
- 115V, 208V or 220V (1 phase).
- 208/230V or /460/575V (3 phase).
- LED indicator lights for oil spill, power, high liquid level, overload and pumps run.
- UL 508 and 778 approved.
- Compliant with ASME A17.1 Elevator Code.

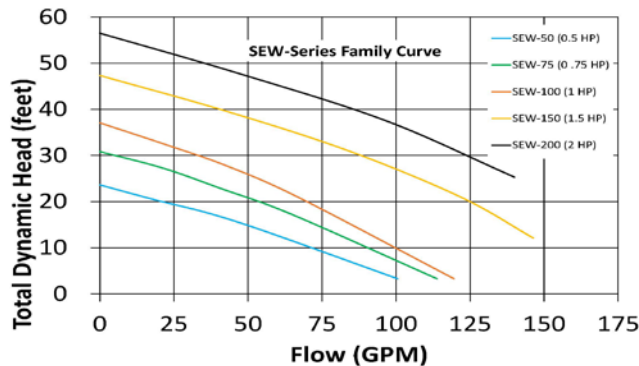
**Performance Curve**

**Electrical Data**

Model	Phase	BHP	Volts	FLA	LRA	NEMA Letter	Pole/Speed (rpm)	Pump Weight	Discharge
SEW-50	1	0.5	115	8.0	40.0	L	2/3450	31lbs (14kg)	2"NPT Female Vertical
	1	0.5	208	4.4	22.0	L	2/3450		
	1	0.5	230	4.0	20.0	L	2/3450		
	3	0.5	208	2.2	11.0	J	2/3450		
	3	0.5	230	2.0	10.0	J	2/3450		
	3	0.5	460	1.0	5.0	J	2/3450		
SEW-75	1	0.75	115	10.5	52.5	K	2/3450	33lbs (15kg)	2"NPT Female Vertical
	1	0.75	208	5.9	29.5	K	2/3450		
	1	0.75	230	5.3	26.5	K	2/3450		
	3	0.75	208	3.5	17.5	K	2/3450		
	3	0.75	230	3.2	16.0	K	2/3450		
	3	0.75	460	1.6	8.0	K	2/3450		
SEW-100	1	1.0	115	13.5	65.0	J	2/3450	36lbs (16kg)	2"NPT Female Vertical
	1	1.0	208	7.2	36.0	J	2/3450		
	1	1.0	230	6.5	32.5	J	2/3450		
	3	1.0	208	4.6	21.0	K	2/3450		
	3	1.0	230	4.2	21.0	K	2/3450		
	3	1.0	460	2.1	10.5	K	2/3450		
SEW-150	1	1.5	115	17.6	88.0	H	2/3450	55lbs (25kg)	2"NPT Female Vertical
	1	1.5	208	10.7	53.5	J	2/3450		
	1	1.5	230	9.7	48.5	J	2/3450		
	3	1.5	208	6.1	30.5	J	2/3450		
	3	1.5	230	5.5	27.5	J	2/3450		
	3	1.5	460	2.8	14.0	J	2/3450		
SEW-200	1	2.0	115	22.0	110.0	G	2/3450	57lbs (26kg)	2"NPT Female Vertical
	1	2.0	208	11.1	55.5	G	2/3450		
	1	2.0	230	10.1	50.5	G	2/3450		
	3	2.0	208	7.7	38.5	H	2/3450		
	3	2.0	230	7.0	35.0	H	2/3450		
	3	2.0	460	3.5	17.5	H	2/3450		
	3	2.0	575	3.0	15.0	J	2/3450		

**Construction**

<b>Motor Design</b>	Induction	<b>Motor Housing</b>	Stainless Steel
<b>Motor Type</b>	Enclosed submersible	<b>Volute</b>	Cast Iron
<b>Insulation Class</b>	Class B	<b>External Hardware</b>	Stainless Steel
<b>Motor Protection</b>	Bi-metallic Thermal Switch	<b>O-Rings</b>	Nitrile (Buna N)
<b>Bi-Metallic Temp Trip</b>	120° C ± 5° C	<b>Motor Shaft</b>	Stainless Steel
<b>Max Fluid temp</b>	104°F (40°C)	<b>Impeller</b>	Cast Iron
<b>Upper Shaft Seal</b>	carbon/ceramic	<b>Lower Shaft Seal</b>	Sic/Sic

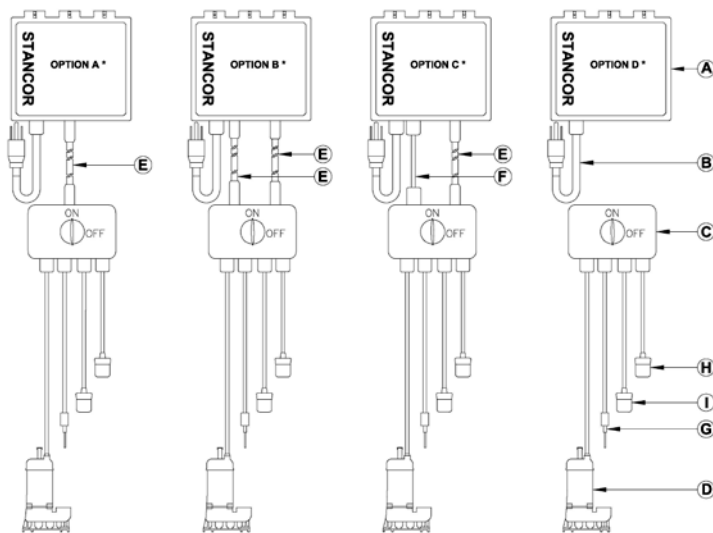
**Configurations**



Item	Description
A	Control Panel
B	Power Cable
C	J-Box + Disconnect
D	Pump
E	8 pin Cable
F	Pump Power Cable
G	Sensor Probe
H	High Alarm Float
I	Pump ON Float

\* See OM Configuration Sheet for specific options

**Installation Dimensions**

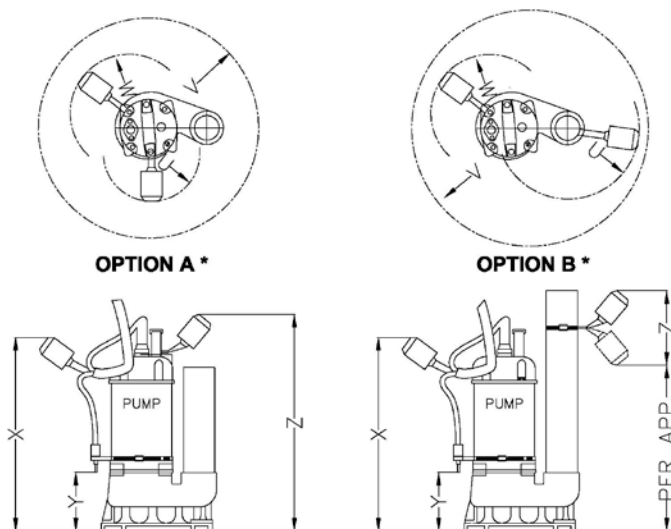

Item	Description
U	HIGH Float radius
V	Minimum Sump $\phi$
W	Pump ON radius
X	Pump ON
Y	Pump OFF
Z	High Alarm

\* See OM Configuration Sheet for specific option and dimensions.