

DIMENSIONS

AVENGER SERIES

SEW-50-200 GR

Dwg: DS-A02-006 Rev: 2 Date: 12/17

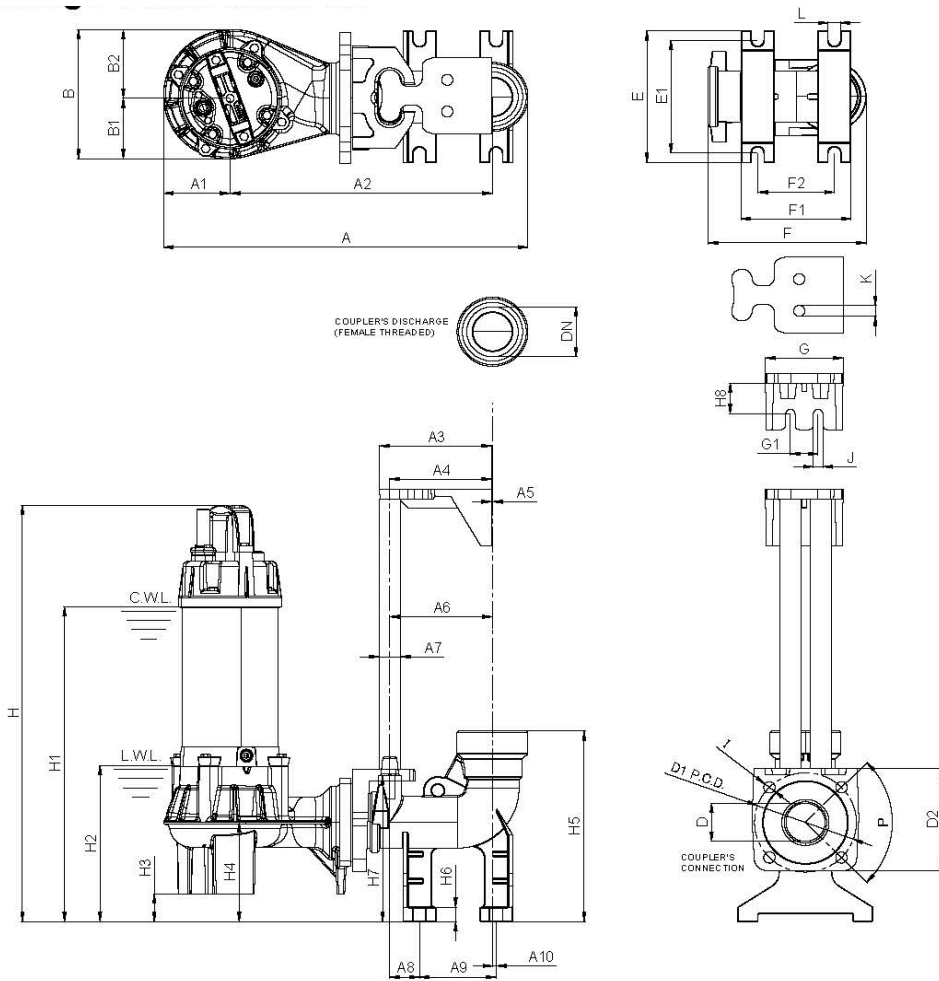

DIMENSIONS -INCH

WEIGHT: lb

MODEL	A	A1	A2	A3	A4	A5	A6	A7	A8	A9	A10	B	B1	B2	D	D1	D2	DN	P	E
SEW-50 (GR)	17.52	4.65	12.6	5.43	4.92	0.04	5.04	3/4	1.38	3.54	0.17	6.46	3.15	3.31	1.97	4.92	5.12	2	90°	6.34
SEW-75 (GR)	17.52	4.65	12.6	5.43	4.92	0.04	5.04	3/4	1.38	3.54	0.17	6.46	3.15	3.31	1.97	4.92	5.12	2	90°	6.34
SEW-100 (GR)	17.52	4.65	12.6	5.43	4.92	0.04	5.04	3/4	1.38	3.54	0.17	6.46	3.15	3.31	1.97	4.92	5.12	2	90°	6.34
SEW-150 (GR)	18.43	5.31	13.39	5.43	4.92	0.04	5.04	3/4	1.38	3.54	0.17	7.32	3.46	3.86	1.97	4.92	5.12	2	90°	6.34
SEW-200 (GR)	18.43	5.31	13.39	5.43	4.92	0.04	5.04	3/4	1.38	3.54	0.17	7.32	3.46	3.86	1.97	4.92	5.12	2	90°	6.34

MODEL	E1	F	F1	F2	G	G1	H	H1	H2	H3	H4	H5	H6	H7	H8	I	J	K	L	WT	WT1
SEW-50 (GR)	5.59	7.72	5.31	3.54	3.78	1.34	20.28	15.24	8.11	1.77	5.31	9.84	0.71	7.72	1.69	M16	0.43	0.51	0.55	34.1	19.8
SEW-75 (GR)	5.59	7.72	5.31	3.54	3.78	1.34	20.91	15.87	8.11	1.77	5.31	9.84	0.71	7.72	1.69	M16	0.43	0.51	0.55	36.3	19.8
SEW-100 (GR)	5.59	7.72	5.31	3.54	3.78	1.34	21.46	16.42	8.11	1.77	5.31	9.84	0.71	7.72	1.69	M16	0.43	0.51	0.55	39.6	19.8
SEW-150 (GR)	5.59	7.72	5.31	3.54	3.78	1.34	21.46	16.06	7.6	1.38	4.92	9.84	0.71	7.72	1.69	M16	0.43	0.51	0.55	58.3	19.8
SEW-200 (GR)	5.59	7.72	5.31	3.54	3.78	1.34	22.24	16.85	7.6	1.38	4.92	9.84	0.71	7.72	1.69	M16	0.43	0.51	0.55	60.5	19.8

C.W.L.:Continuous Running Water Level

L.W.L.:Lowest Running Water Level

WT: Pump Weight

WT1: Q.D.C. Weight

Specifications subject to change without notice