

SG-150

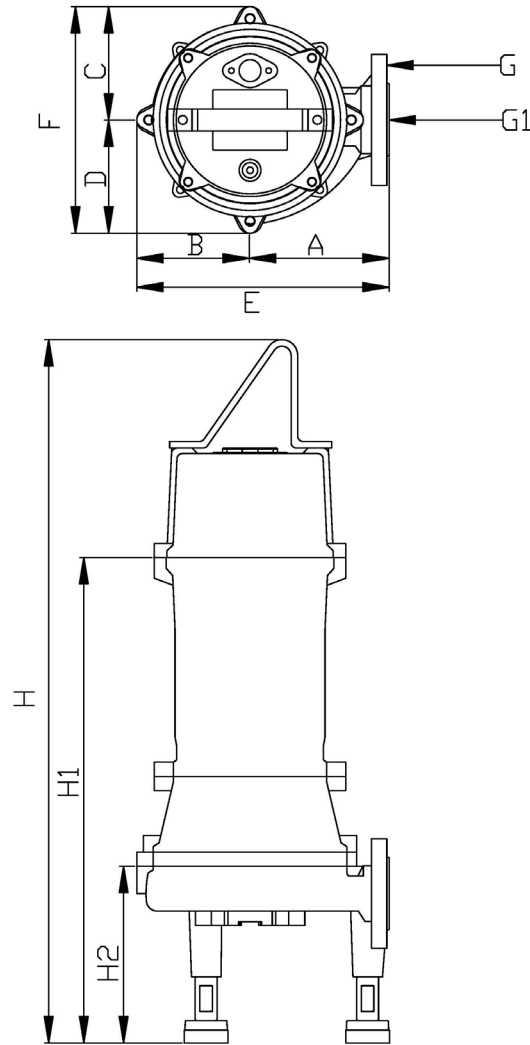

Type	A	B	C	D	E	F
Dimensions	5.04"	4.02"	4.06"	4.06"	9.06"	8.11"
Type	G	G1	H	H1	H2	
Dimensions	1.25" Class# 125lbs F.F.	1.25" NPT Female	25.2"	17.52"	6.3"	

Specifications subject to change without notice

SG-200

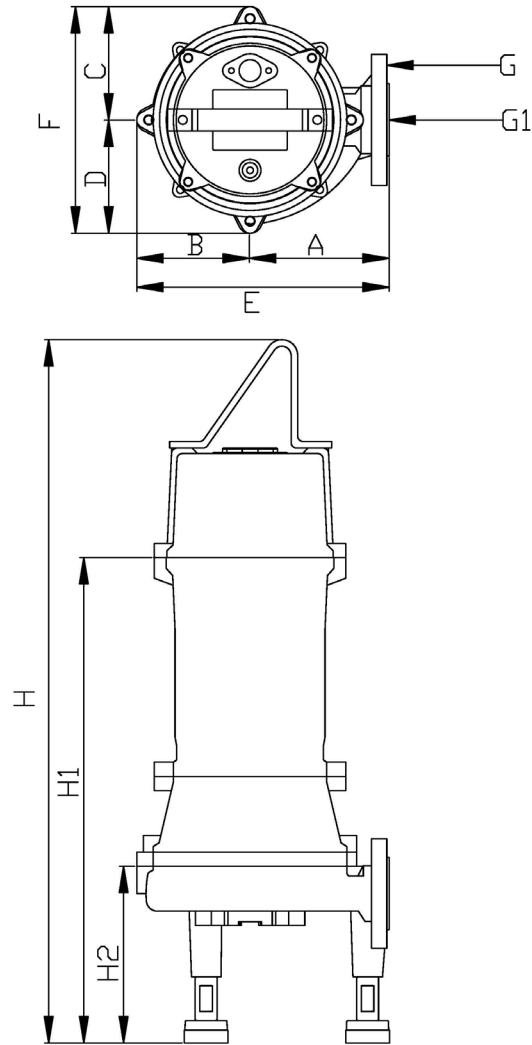

Type	A	B	C	D	E	F
Dimensions	5.04"	4.02"	4.06"	4.06"	9.06"	8.11"
Type	G	G1	H	H1	H2	
Dimensions	1.25" Class# 125lbs F.F.	1.25" NPT Female	25.2"	17.52"	6.3"	

Specifications subject to change without notice

SG-300

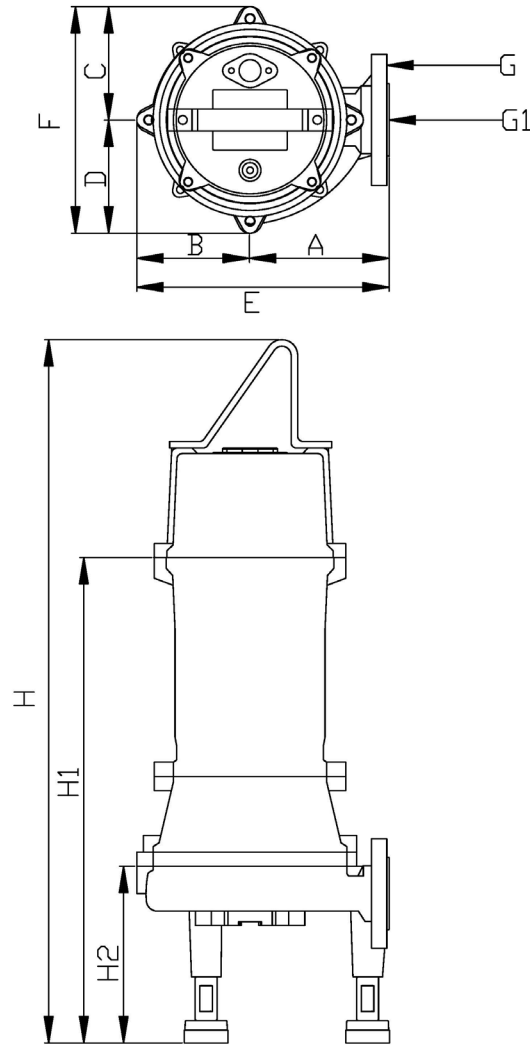

Type	A	B	C	D	E	F
Dimensions	5.04"	4.02"	4.06"	4.06"	9.06"	8.11"
Type	G	G1	H	H1	H2	
Dimensions	1.25" Class# 125lbs F.F.	1.25" NPT Female	26.77"	19.09"	6.3"	

Specifications subject to change without notice

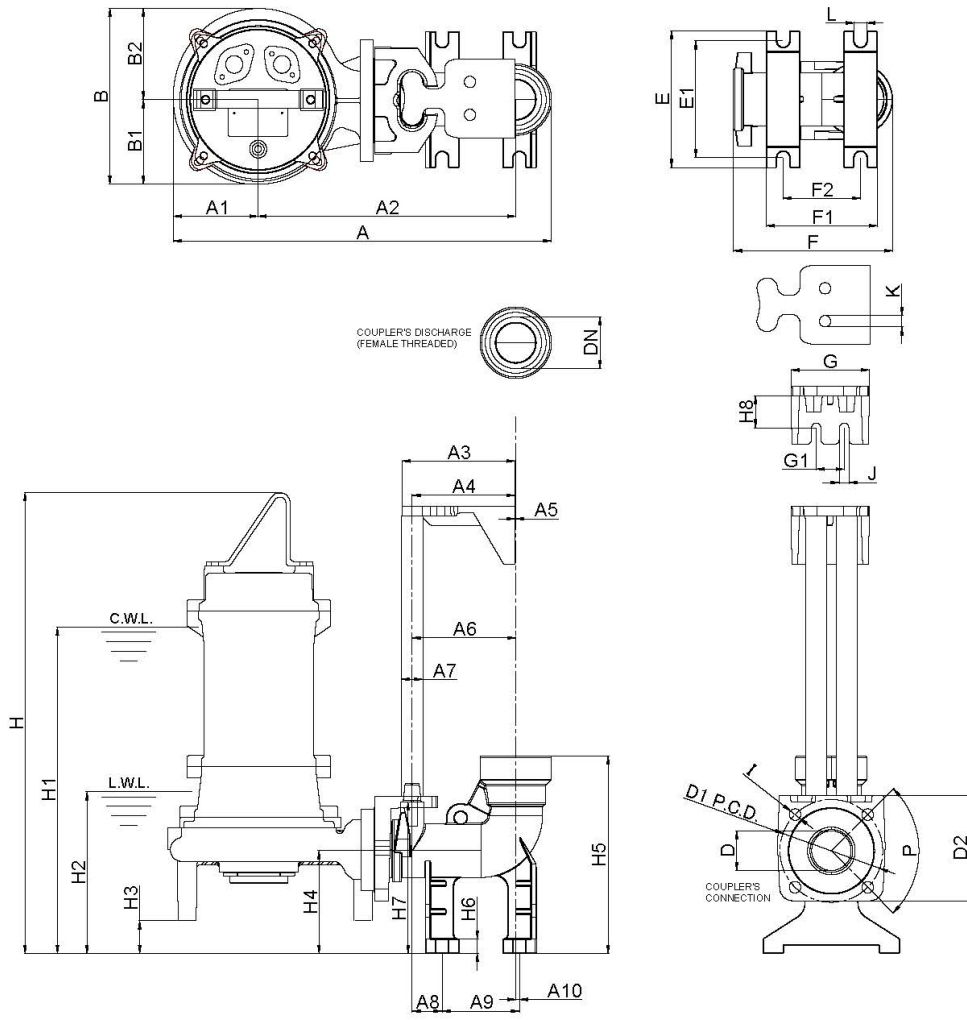

PIPE CONNECTION TYPES
NPT

DIMENSIONS -INCH

WEIGHT: lb

MODEL	A	A1	A2	A3	A4	A5	A6	A7	A8	A9	A10	B	B1	B2	D	D1	D2	DN	P	E
SG-500	19.69	4.69	13.28	5.43	4.92	0.04	5.04	3/4	1.38	3.54	0.17	9.41	4.49	4.92	1.97	4.92	5.12	2	90°	6.34
SG-750	19.69	4.69	13.28	5.43	4.92	0.04	5.04	3/4	1.38	3.54	0.17	9.41	4.49	4.92	1.97	4.92	5.12	2	90°	6.34

MODEL	E1	F	F1	F2	G	G1	H	H1	H2	H3	H4	H5	H6	H7	H8	I	J	K	L	WT	WT1
SG-500	5.59	7.72	5.31	3.54	3.78	1.34	25.08	18.78	6.06	1.14	4.92	9.84	0.71	7.72	1.69	M12	0.43	0.51	0.55	96.8	19.8
SG-750	5.59	7.72	5.31	3.54	3.78	1.34	26.65	20.35	6.06	1.14	4.92	9.84	0.71	7.72	1.69	M12	0.43	0.51	0.55	107.8	19.8

C.W.L.:Continuous Running Water Level

L.W.L.:Lowest Running Water Level

WT: Pump Weight

WT1: Q.D.C Weight