

List of Parts (SSD-75&100)

NO	Name	Mtrl	Photo	NO	Name	Mtrl	Photo
1	Cable	H07/UL		13	Protector (1 Phase)		
2	Handle	Steel		13	Protector (3 Phase)		
3	Motor Cover	ADC12		14	Capacitor		
4	Bracket	Steel		15	Bearing		
5	Motor Housing +Stator	ADC12		16	Strainer	SUS 304	
6	Shaft with Rotor	SUS 410		17	O-ring	NBR	
7	Oil Chamber	ADC12		18-3	Wearing Plate	PA66+20% GF	
8	Mech. Seal	SIC/SIC		18-4	Volute Liner	NBR	
10	Oil Seal	NBR		21	Float Switch (Optional)		
11	Impeller	Hytrel		27	Flange	FC 15	
12	Pump Casing	FC 20		30	Pump Housing	SUS 304	
NO	Name	Mtrl	NO	Name	Mtrl		
18	Gasket	NBR	20	Washer	SUS 304		
18-1	Gasket	NBR	22	Screw with O-ring			
18-2	Gasket	NBR	23	Cable Seat			
19	Screw	SUS 304	26	T adapter (Optional)			
19-1	Screw	SUS 304	29	Insulating Paper			
19-2	Screw	SUS 304	31	Nut	SUS 304		
19-3	Screw	SUS 304	31-1	Nut	SUS 304		
19-4	Screw	SUS 304	33	Spring Washer	SUS 304		
19-5	Screw	SUS 304	33-1	Spring Washer	SUS 304		
19-6	Screw	SUS 304	34	Corrugated Spring	Steel		
19-7	Screw	SUS 304	35	Sleeve	SUS 304		

Exploded View (SSD-75&100)

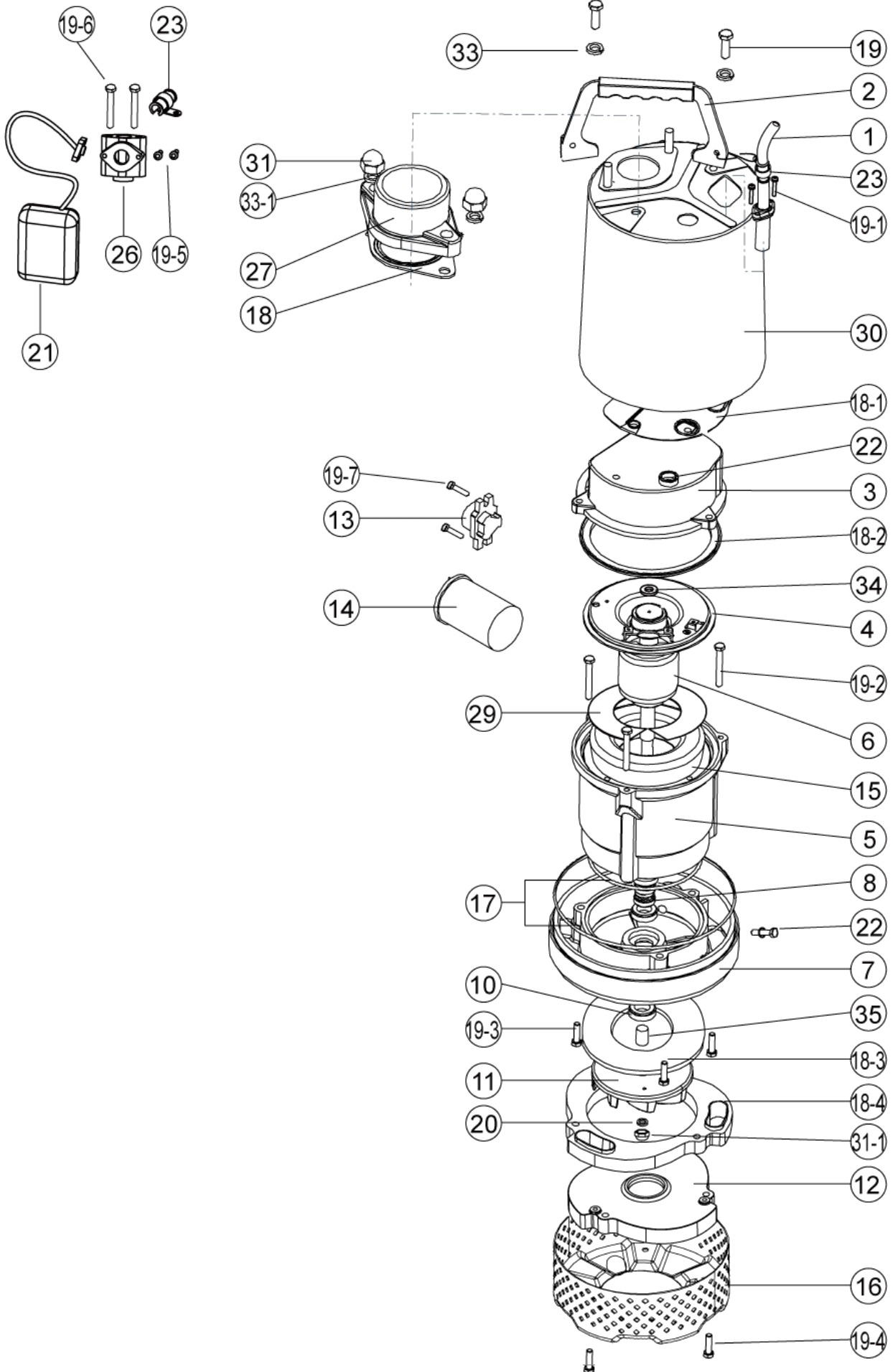

List of Parts (SSD-200)

NO	Name	Mtrl	Photo	NO	Name	Mtrl	Photo
1	Cable	H07/UL		13	Protector (1 Phase)		
2	Handle	Steel		13	Protector (3 Phase)		
3	Motor Cover	ADC12		14	Capacitor		
4	Bracket	Steel		15	Bearing		
5	Motor Housing +Stator	ADC12		16	Strainer	SUS 304	
6	Shaft with Rotor	SUS 410		17	O-ring	NBR	
7	Oil Chamber A	A356		18-3	Wearing Plate	PA66+20% GF	
7-1	Oil Chamber B	A356		18-4	Gasket	NBR	
8	Mech. Seal	SIC/SIC		21	Float Switch (Optional)		
10	Oil Seal	NBR		27	Flange	FC 15	
11	Impeller	Hytrel		30	Pump Housing	SUS 304	
12	Pump Casing	FC 20					

NO	Name	Mtrl	NO	Name	Mtrl
18	Gasket	NBR	19-9	Screw	SUS 304
18-1	Gasket	NBR	20	Washer	
18-2	Gasket	NBR	22	Screw with O-ring	
19	Screw	SUS 304	23	Cable Seat	
19-1	Screw	SUS 304	26	T adapter (Optional)	
19-2	Screw	SUS 304	29	Insulating Paper	
19-3	Screw	SUS 304	31	Nut	SUS 304
19-4	Screw	SUS 304	31-1	Nut	SUS 304
19-5	Screw	SUS 304	33	Spring Washer	SUS 304
19-6	Screw	SUS 304	33-1	Spring Washer	SUS 304
19-7	Screw	SUS 304	34	Corrugated Spring	Steel
19-8	Screw	SUS 304	35	Sleeve	SUS 304

Exploded View (SSD-200)

