

Construction

Motor Design	Induction	Motor Housing	Stainless Steel
Motor Type	Enclosed submersible	Volute	Cast Iron
Insulation Class	Class B	External Hardware	Stainless Steel
Motor Protection	Bi-metallic Thermal Switch	O-Rings	Nitrile (Buna N)
Bi-Metallic Temp Trip	120° C ± 5° C	Motor Shaft	Stainless Steel
Max Fluid temp	104°F (40°C)	Impeller	Cast Iron
Upper Shaft Seal	Carbon/Ceramic	Lower Shaft Seal	Sic/Sic

Configurations

Configuration

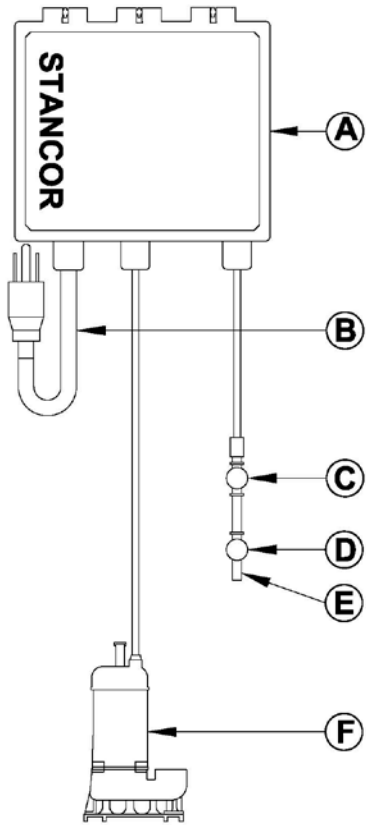

Dimensions

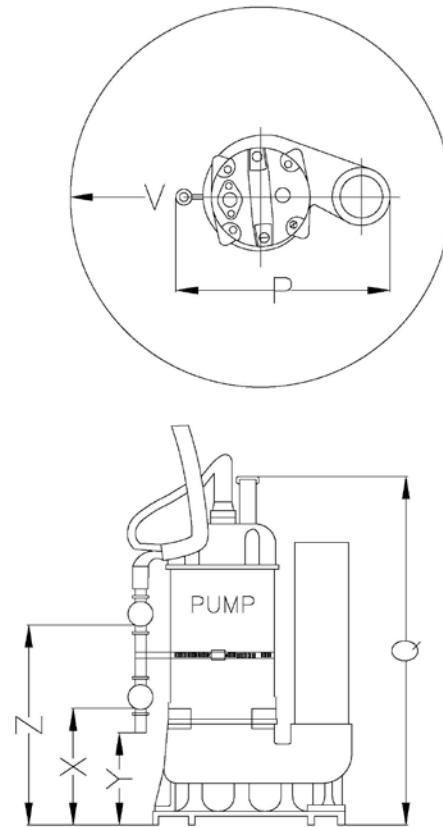

Item	Description
A	Control Panel
B	Power Cable*
C	HIGH Float**
D	ON Float**
E	Sensor Probe**
F	Pump**

Description	Item	SE-40	SE-50	SE-100
Pump with OM-300	P	11.59"	11.59"	11.59"
Height to Handle	Q	15.59"	16.57"	19.53"
Minimum Sump ø	V	12.09"	12.09"	12.09"
Pump ON L* / S**	X	8.05" / 5"	8.05" / 5"	8.05" / 5"
Pump OFF	Y	3.25"	3.25"	3.25"
High Alarm L*/S**	Z	11.05" / 8"	11.05" / 8"	11.05" / 8"

*Single Phase only, 6' Standard.

**16' Standard (Consult Factory for Additional Lengths).

*OM-300L Standard Option

** OM-300S Low Level Option

Factory minimum recommended sump size is 2' x 2' x 2'.