

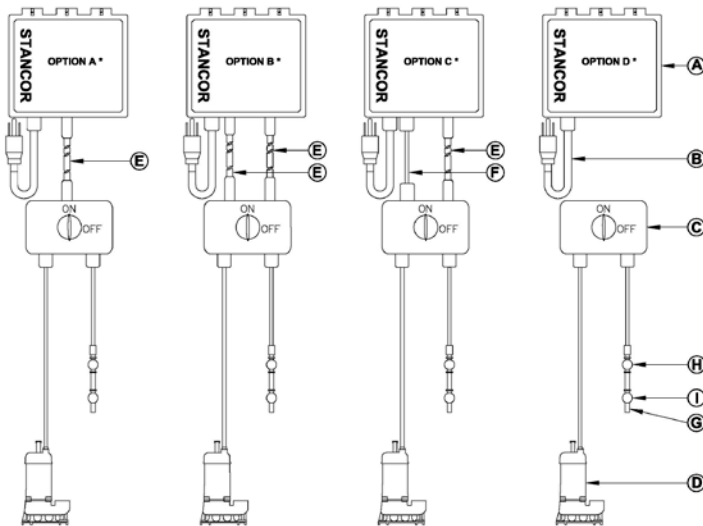

**Construction**

<b>Motor Design</b>	Induction	<b>Motor Housing</b>	Stainless Steel
<b>Motor Type</b>	Enclosed submersible	<b>Volute</b>	Stainless Steel
<b>Insulation Class</b>	Class B	<b>External Hardware</b>	Stainless Steel
<b>Motor Protection</b>	Bi-metallic Thermal Switch	<b>O-Rings</b>	FKM
<b>Bi-Metallic Temp Trip</b>	120° C ± 5° C	<b>Motor Shaft</b>	Stainless Steel
<b>Max Fluid temp</b>	104°F (40°C)	<b>Impeller</b>	Stainless Steel
<b>Upper Shaft Seal</b>	carbon/ceramic	<b>Lower Shaft Seal</b>	Sic/Sic

**Configurations**



Item	Description
A	Control Panel
B	Power Cable
C	J-Box + Disconnect
D	Pump
E	8 pin Cable
F	Pump Power Cable
G	Sensor Probe
H	High Alarm Float
I	Pump ON Float

\* See OM Configuration Sheet for specific options

**Installation Dimensions**

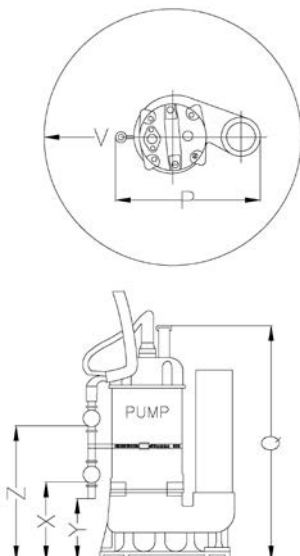

Item	Description
P	Pump Size
Q	Height to Handle
V	Minimum Sump $\phi$
X	Pump ON
Y	Pump OFF
Z	High Alarm

\* See OM Configuration Sheet for specific option and dimensions.