

Construction

Motor Design	Induction	Motor Housing	Stainless Steel
Motor Type	Enclosed submersible	Volute	Stainless Steel
Insulation Class	Class B	External Hardware	Stainless Steel
Motor Protection	Bi-metallic Thermal Switch	O-Rings	FKM
Bi-Metallic Temp Trip	120° C ± 5° C	Motor Shaft	Stainless Steel
Max Fluid temp	104°F (40°C)	Impeller	Stainless Steel
Upper Shaft Seal	carbon/ceramic	Lower Shaft Seal	Sic/Sic

Configuration

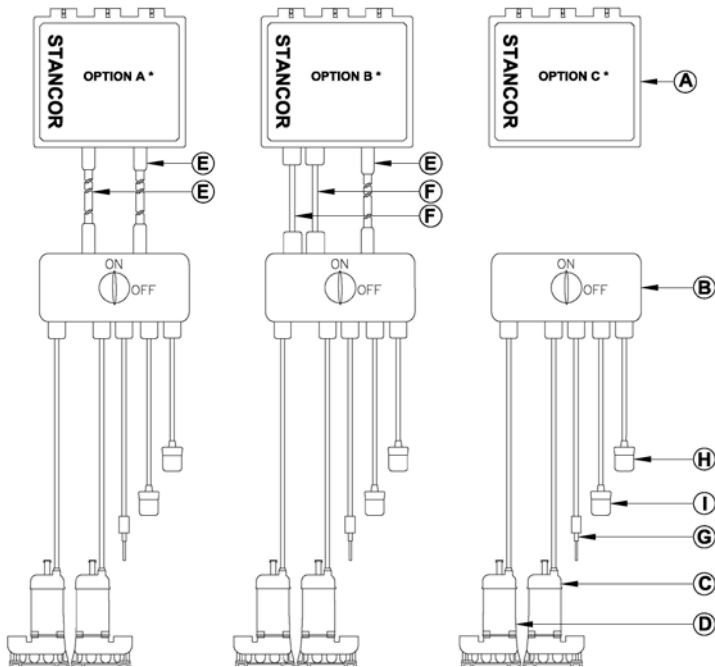

Item	Description
A	Control Panel
B	J-Box + Disconnect
C	Pump A
D	Pump B
E	8 Pin Cable
F	Pump Power Cable
G	Sensor Probe
H	High Float
I	ON Float

* See OM Configuration Sheet for specific option

Installation Dimensions

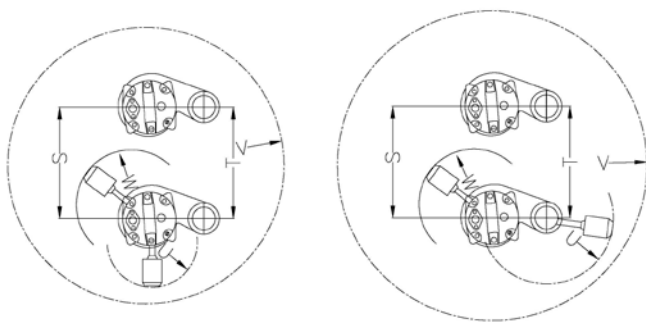

Item	Description
S	Min. Pump Dist.**
T	Min. Fitting Dist.***
U	High Float Radius
V	Min. Sump ϕ
W	ON Float Radius
X	Pump ON
Y	Pump OFF
Z	High Alarm

* See OM Configuration Sheet for specific option and dimensions.

**Minimum distance required for proper pump performance.

***Fitting dimensions are based on ANSI/ASME B16.3 standards.

