

DESIGN / CONSTRUCTION

Overwatch Body	304L SS
External Hardware	304L SS
Gaskets	Buna-N
Motor Body	Cast Iron
Shaft Seal	Single Mechanical Seal
Impeller	200mm DIPCUT® Impeller Standard (Vortex or Channel optional)
Maximum Solid Size \varnothing	4.3" (110 mm)

MOTOR SPECIFICATIONS

Motor Design	4-Pole, 3-Phase Squirrel-Cage Motor 50Hz/60Hz
Motor Type	TEFC, IP67
Insulation Class	Class F
Motor Protection	Protected by VFD
Service Factor	1.15
Maximum Ambient Temp.	104°F (40°C)
Voltage Tolerance	±10%

MOTOR DATA

Rated Power	230V FLA	460V FLA	575V FLA	Weight *
5.5kW / 7.4HP	21.6	10.8	8.6	487lb (221kg)
7.5kW / 10.1HP	29	14.5	11.6	528lb (240kg)
11kW / 14.8HP	44	22	17.6	686lb (311kg)
15kW / 20.1HP	58	29	23.2	820lb (372kg)

DIMENSIONS (largest motor)

Inlet	8" ANSI 150#
Outlet	6" ANSI 150#
H1	18" (457mm)
H2	17.1" (434mm)
L	40.6" (1031mm)
P	37" (943mm)

* Total weight of unit

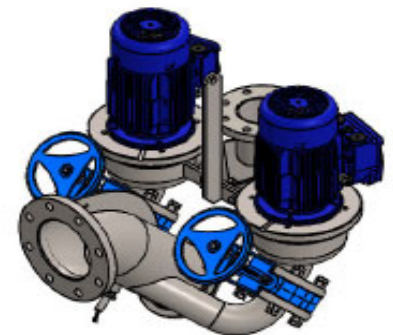
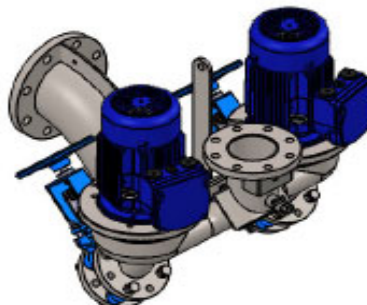
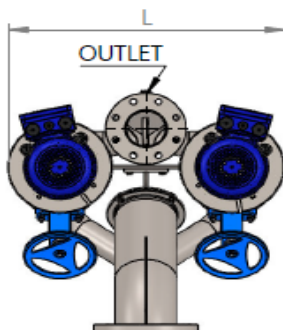
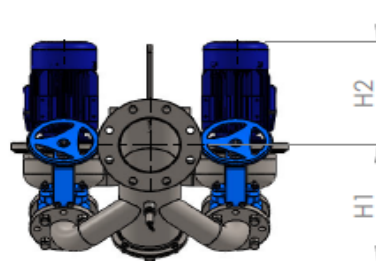
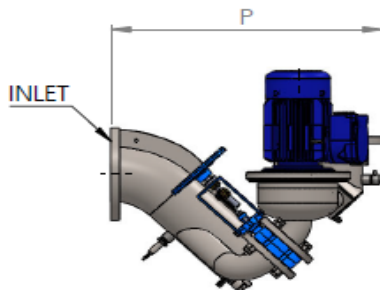

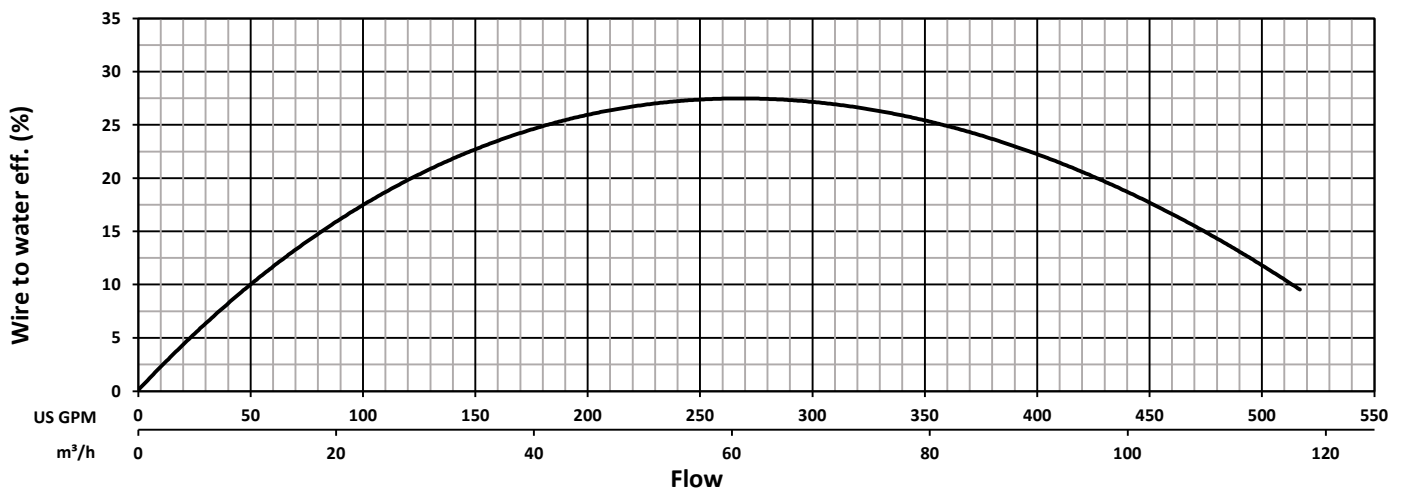
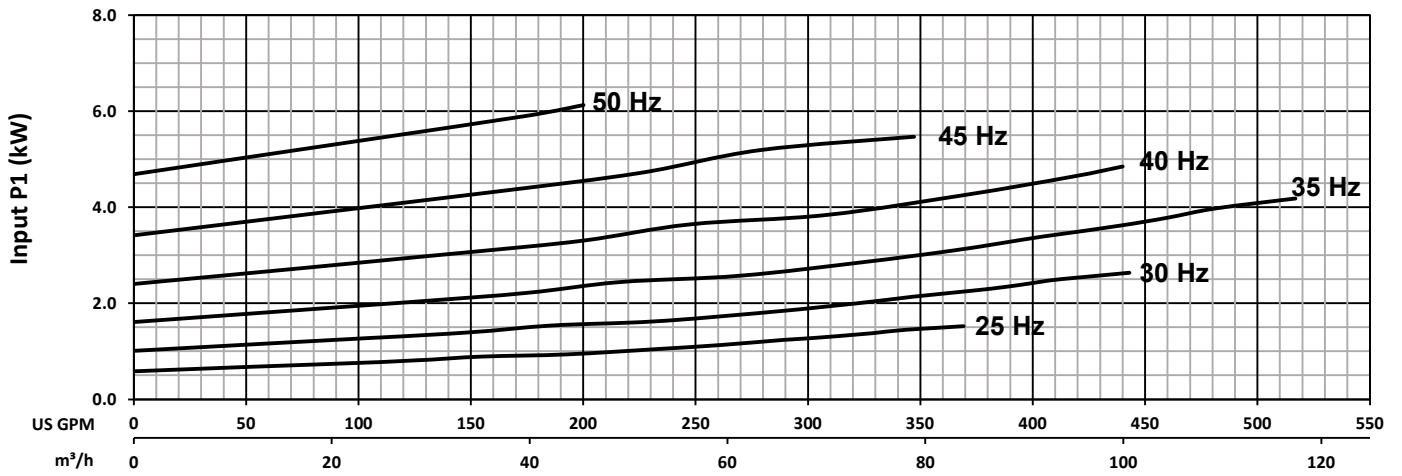
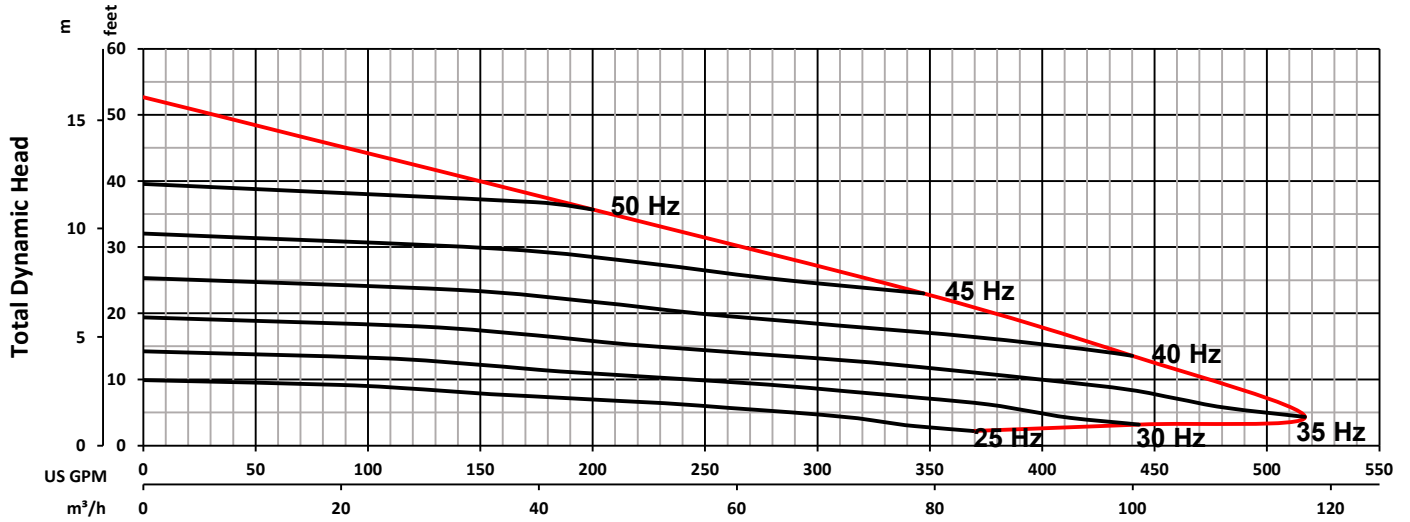

PERFORMANCE CURVE OW101-4VV DC 5.5kW

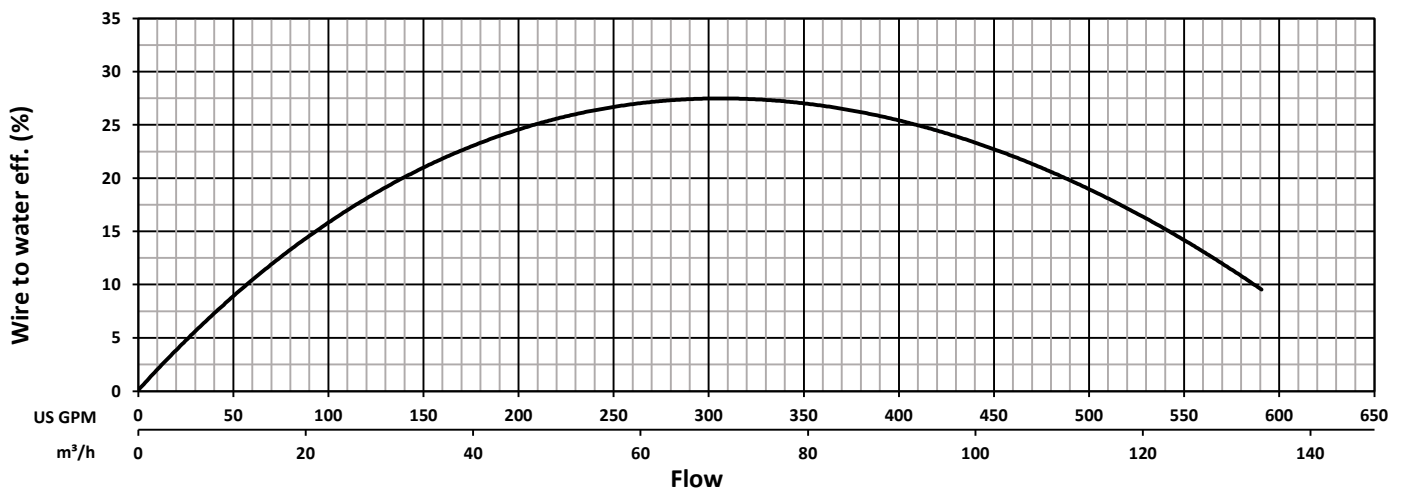
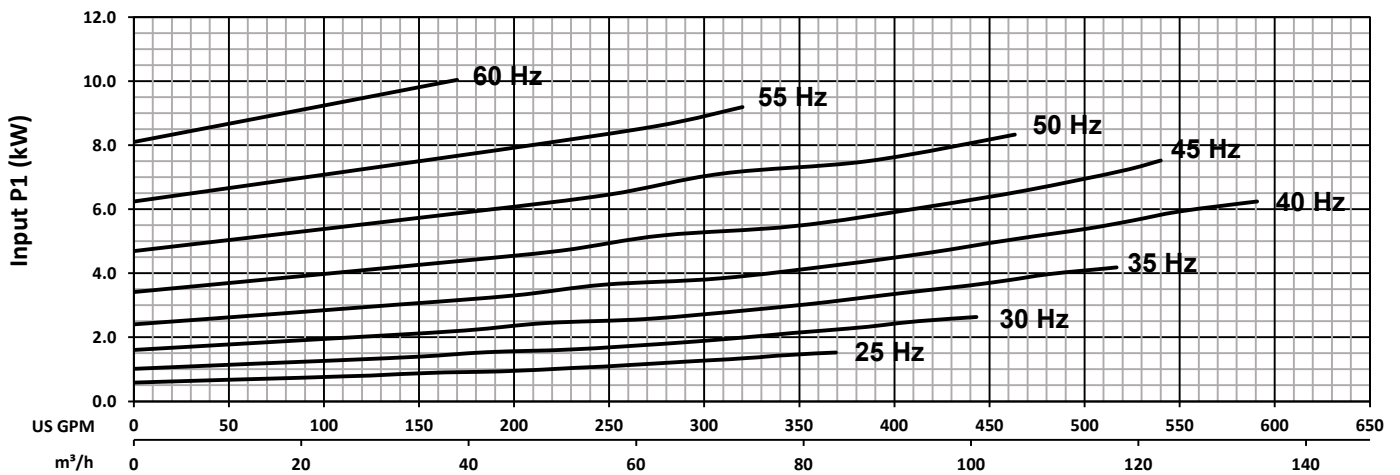
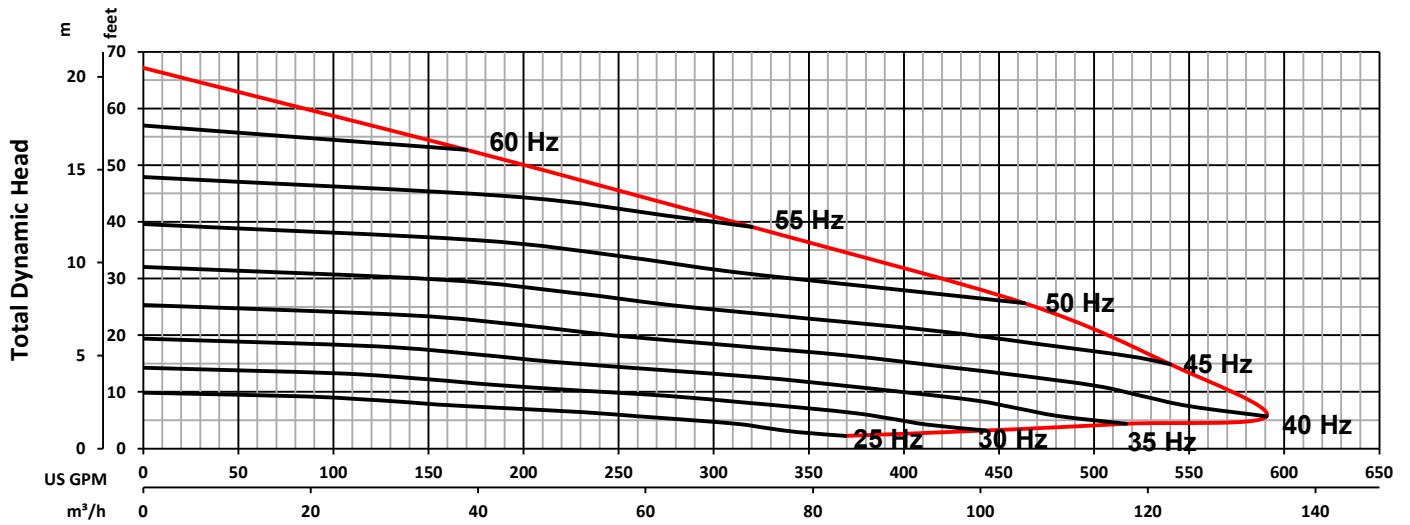

 INDUSTRIAL FLOW SOLUTIONS	PERFORMANCE CURVE OW101-4VV DC 5.5kW			DS-A50-205	
	Tested with clean water Test Standard : HI 11.6 Gr 3B		Model	OW101-4VV	
			Motor	5.5kW / 7.4HP	Poles 4
			Impeller Ø	200x50mm	Specifications subject to change without notice
				Rev --	IC
				Date 4/13/2021	

PERFORMANCE CURVE OW101-4VV DC 7.5kW



 INDUSTRIAL FLOW SOLUTIONS	PERFORMANCE CURVE OW101-4VV DC 7.5kW			DS-A50-204	
	Tested with clean water Test Standard : HI 11.6 Gr 3B		Model	OW101-4VV	
			Motor	7.5kW / 10.1HP	Poles 4
			Impeller Ø	200x50mm	Specifications subject to change without notice
			Rev --	IC	
			Date	4/13/2021	

PERFORMANCE CURVE OW101-4VV VX 7.5kW

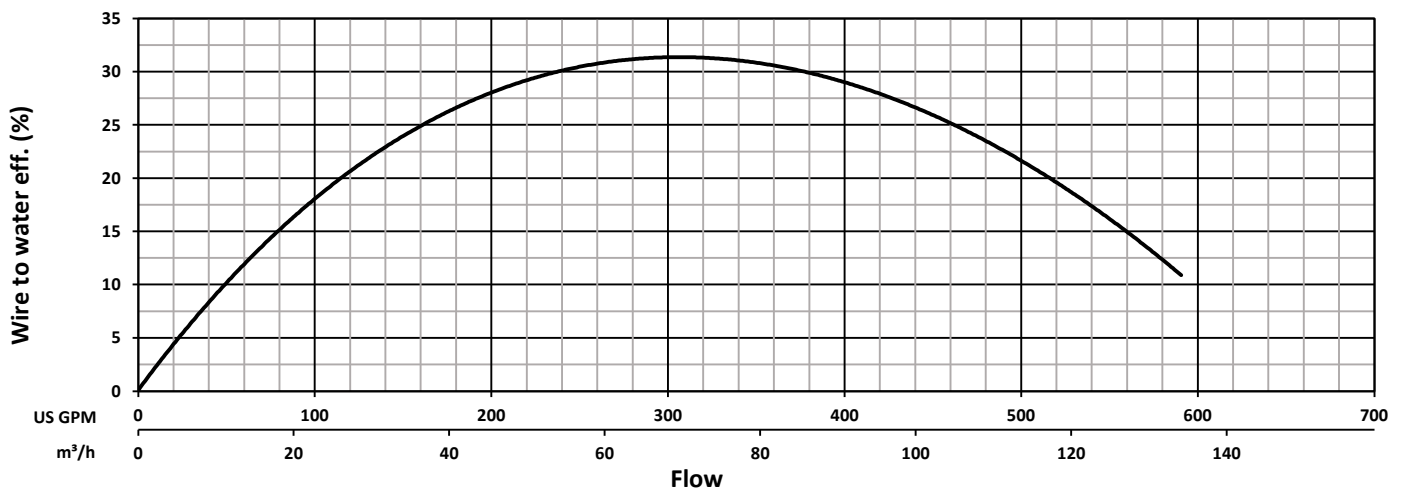
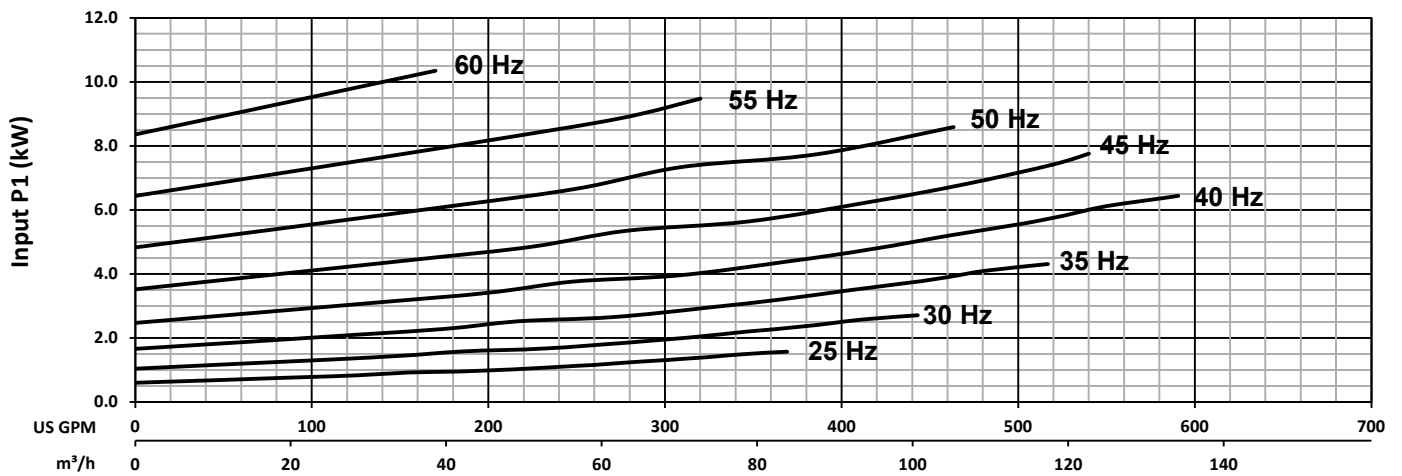
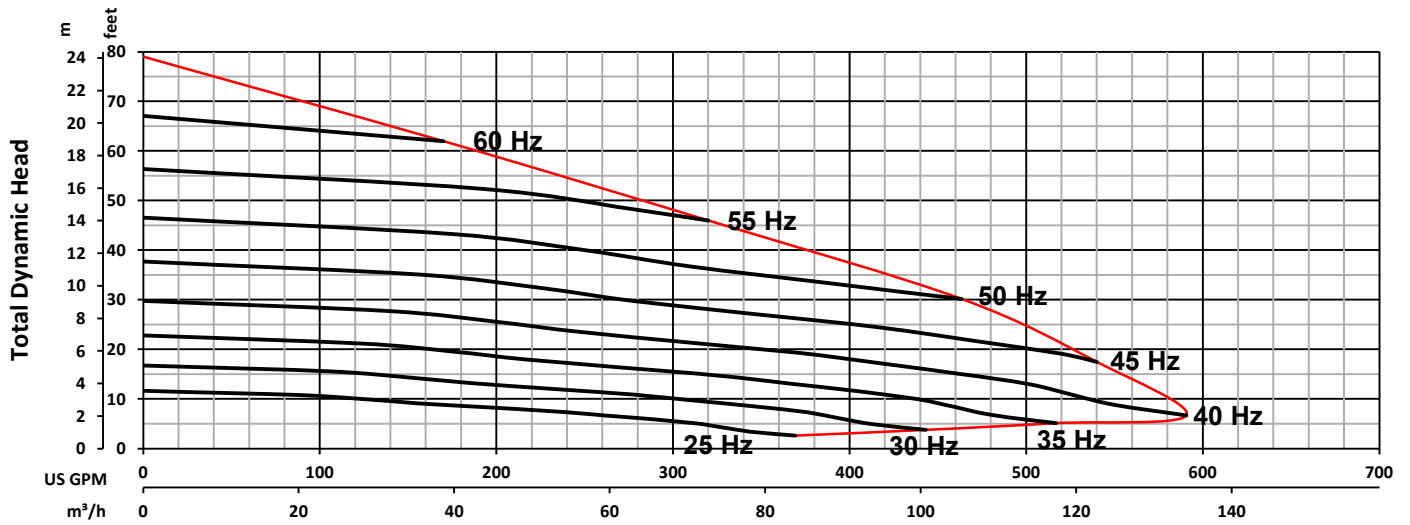

 INDUSTRIAL FLOW SOLUTIONS	PERFORMANCE CURVE OW101-4VV VX 7.5kW			DS-A50-020	
	Tested with clean water Test Standard : HI 11.6 Gr 3B		Model	OW101-4VV	
			Motor	7.5kW / 10.1HP	Poles 4
			Impeller Ø	200x50x30mm	Specifications subject to change without notice
			Rev 1	SCID	
			Date	3/22/2021	

PERFORMANCE CURVE OW101-4VV VX 5.5kW

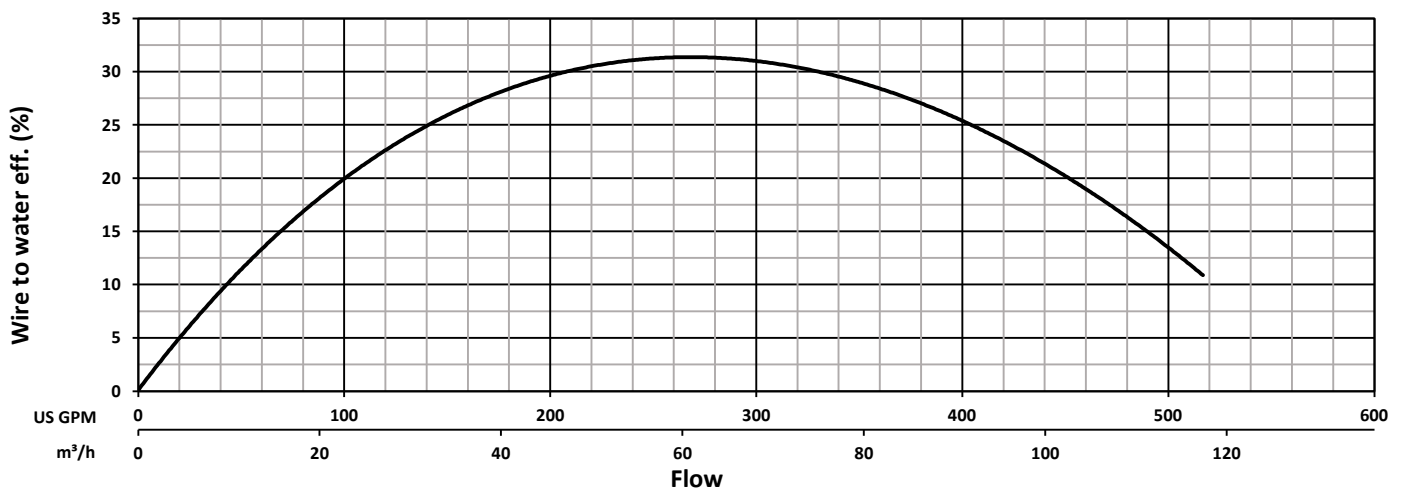
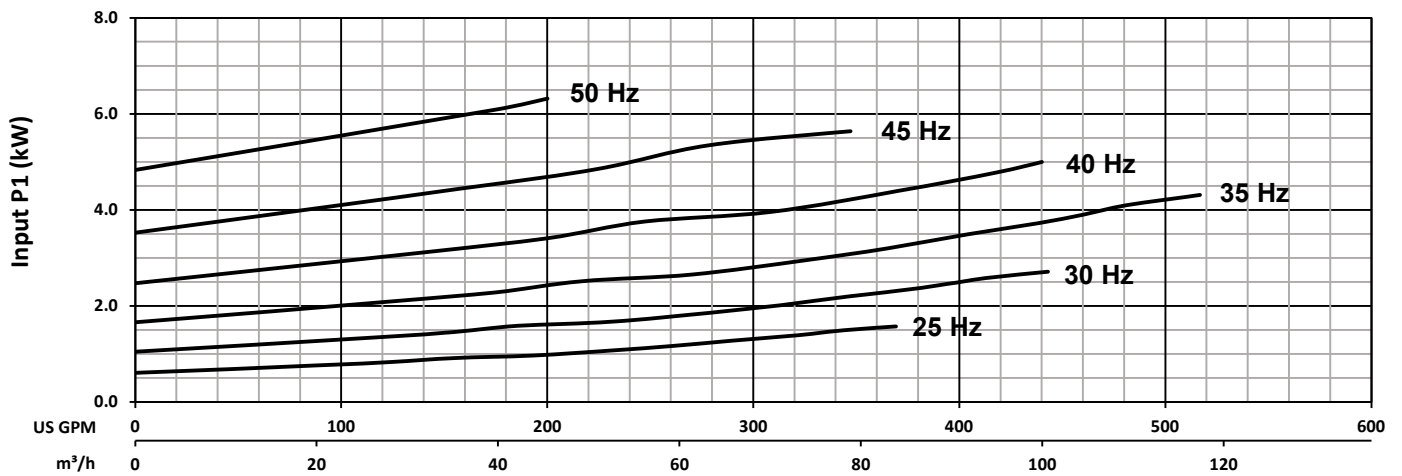
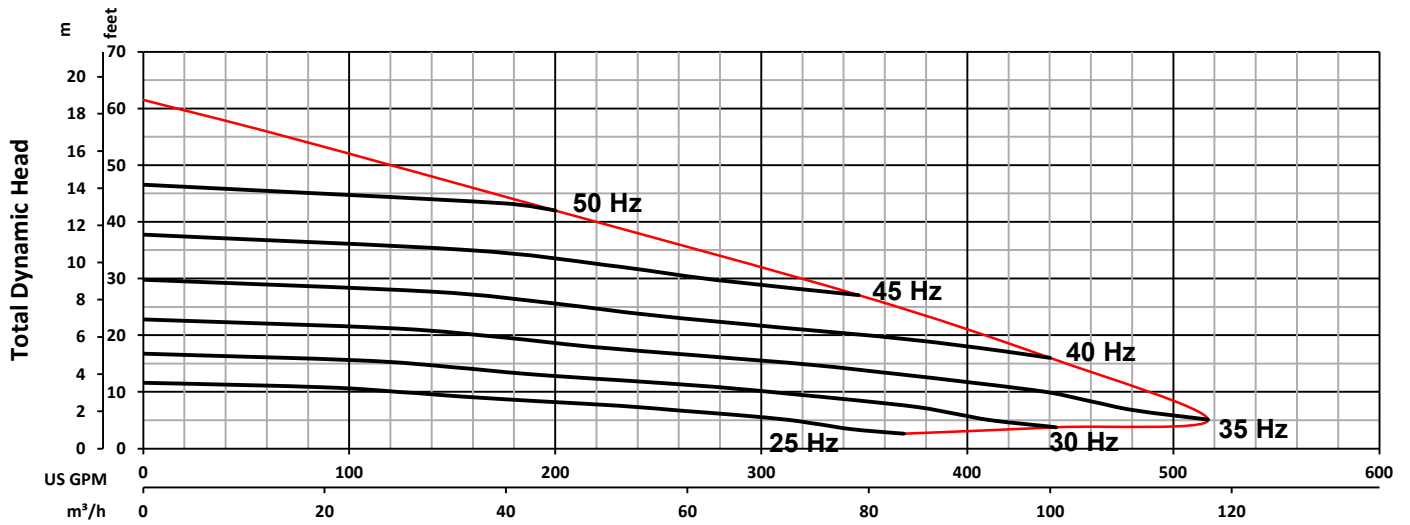

 INDUSTRIAL FLOW SOLUTIONS	PERFORMANCE CURVE OW101-4VV VX 5.5kW			DS-A50-019			
	Tested with clean water Test Standard : HI 11.6 Gr 3B	Model	OW101-4VV		Rev	1 SCID	
		Motor	5.5kW / 7.4HP	Poles	4	Date	3/22/2021
		Impeller Ø	200x50x30mm	Specifications subject to change without notice			