



DESIGN / CONSTRUCTION

Overwatch Body	304L SS
External Hardware	304L SS
Gaskets	Buna-N
Motor Body	Cast Iron
Shaft Seal	Single Mechanical Seal
Impeller	110mm Vortex Impeller Standard
Maximum Solid Size ϕ	2.0" (55mm)

MOTOR SPECIFICATIONS

Motor Design	2-Pole, 3-Phase Squirrel-Cage Motor 50Hz/60Hz
Motor Type	TEFC, IP67
Insulation Class	Class F
Motor Protection	Protected by VFD
Service Factor	1.15
Maximum Ambient Temp.	104°F (40°C)
Voltage Tolerance	±10%

MOTOR DATA

Rated Power	230V FLA	460V FLA	575V FLA	Weight *
1.5kW / 2HP	6	3	2.4	185lb (84kg)
2.2kW / 3HP	8.8	4.4	3.5	194lb (88kg)

DIMENSIONS (largest motor)

Inlet	5" ANSI 150#
Outlet	3" ANSI 150#
H1	11.0" (279mm)
H2	7.5" (192mm)
L	24.0" (610mm)
P	22.4" (569mm)

* Total weight of unit

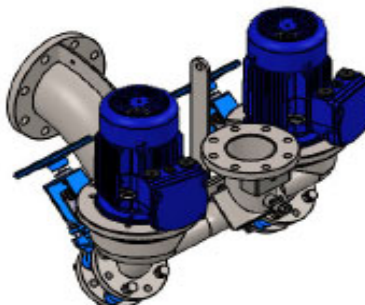
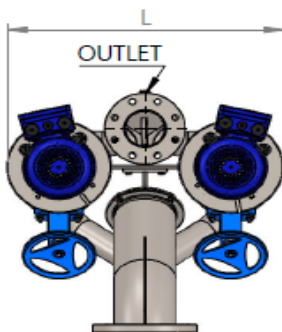
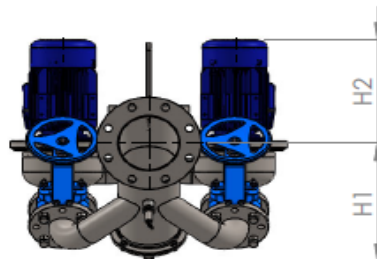
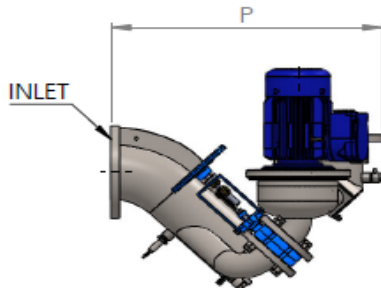

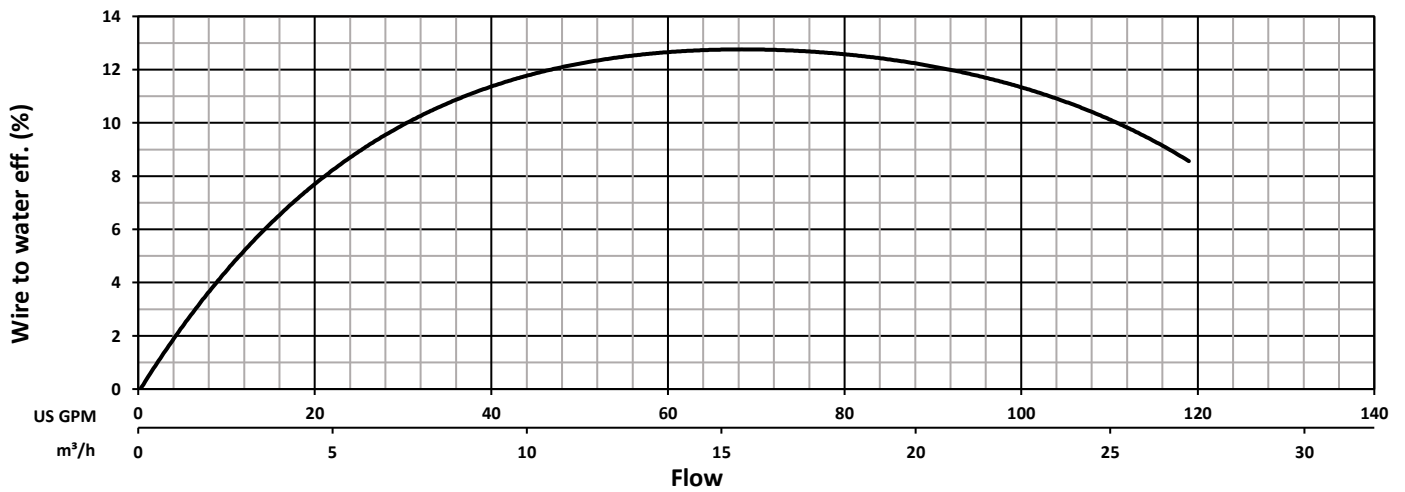
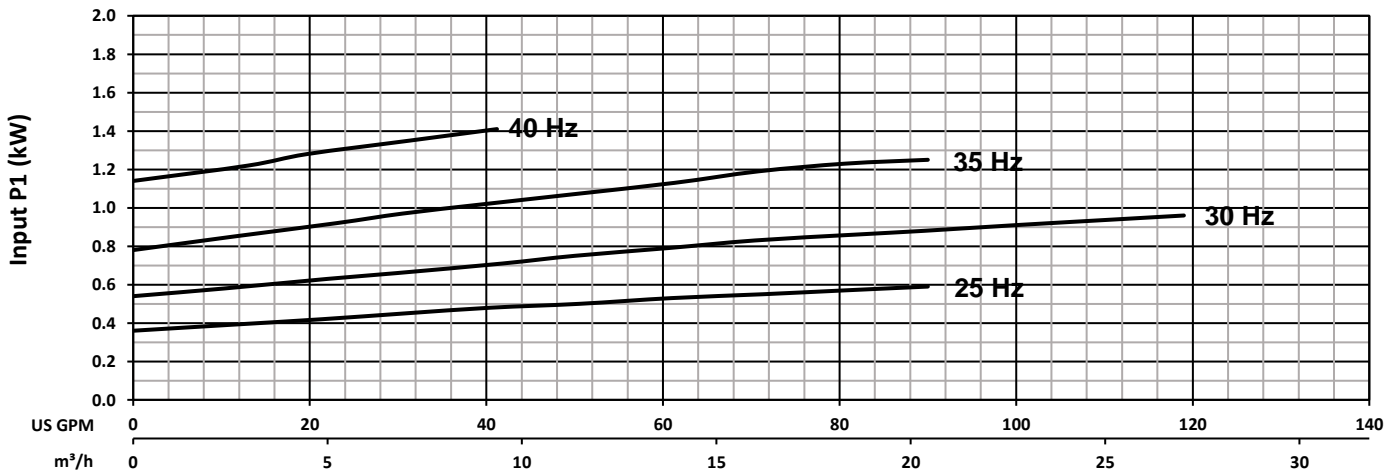
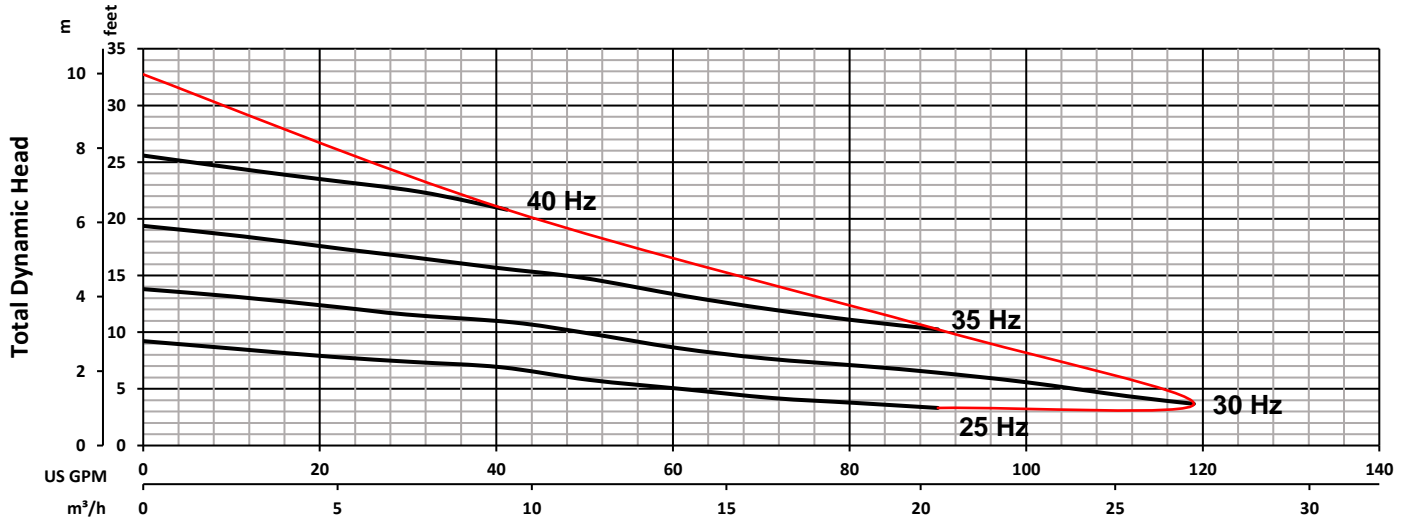

PERFORMANCE CURVE OW11-2VV DC 1.5kW

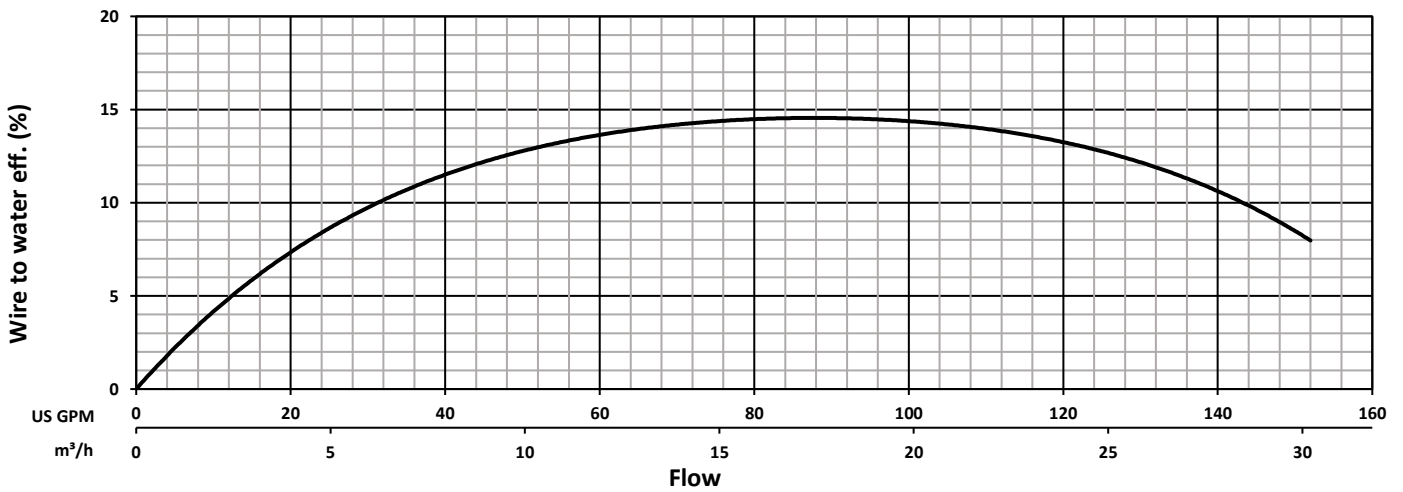
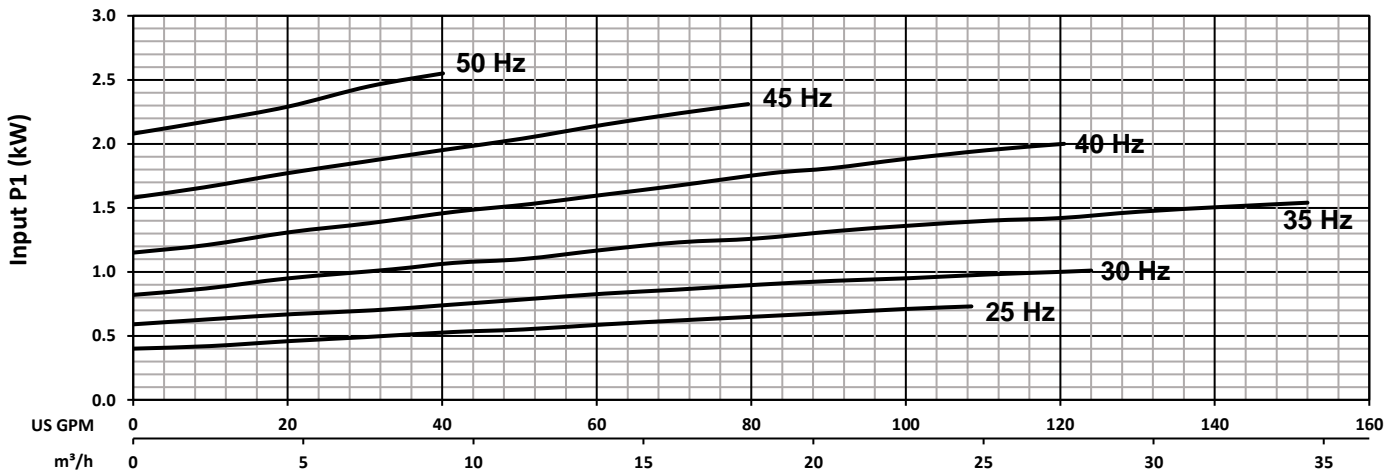
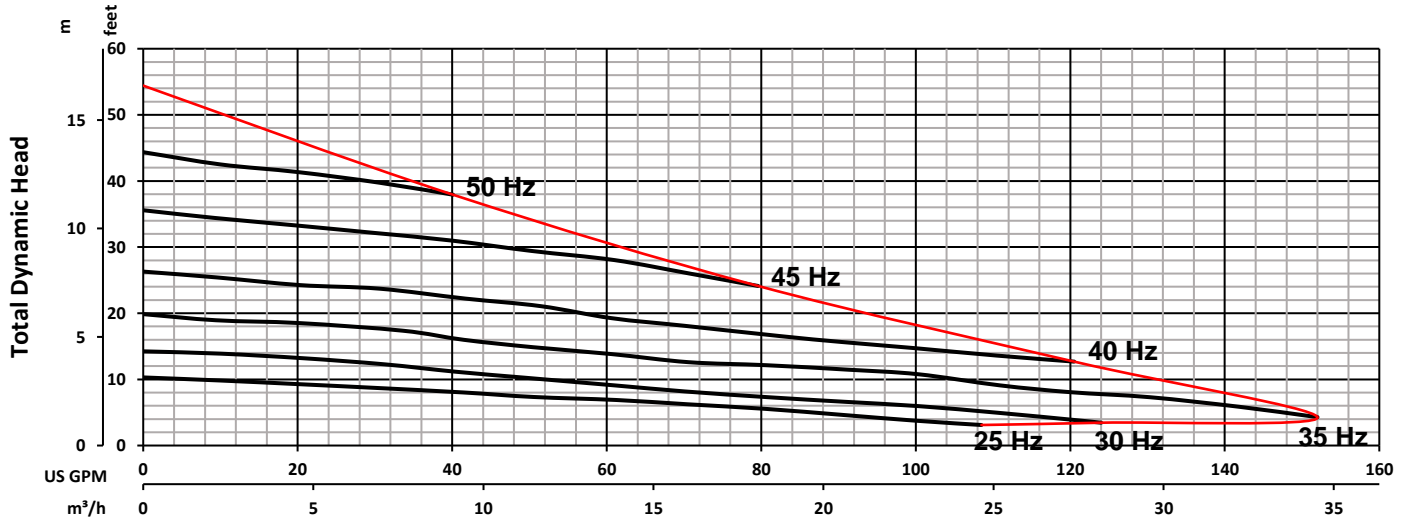

 INDUSTRIAL FLOW SOLUTIONS	PERFORMANCE CURVE OW11-2VV DC 1.5kW			DS-A50-218
	Tested with clean water Test Standard : HI 11.6 Gr 3B		Model	OW11-2VV
			Motor	1.5kW / 2HP
			Impeller	110x25mm

PERFORMANCE CURVE OW11-2VV DC 2.2kW



 INDUSTRIAL FLOW SOLUTIONS	PERFORMANCE CURVE OW11-2VV DC 2.2kW			DS-A50-196
	Tested with clean water Test Standard : HI 11.6 Gr 3B		Model	OW11-2VV
			Motor	2.2kW / 2.9HP
	Tested with clean water Test Standard : HI 11.6 Gr 3B		Impeller	110x25mm

PERFORMANCE CURVE OW11-2VV VX 2.2kW

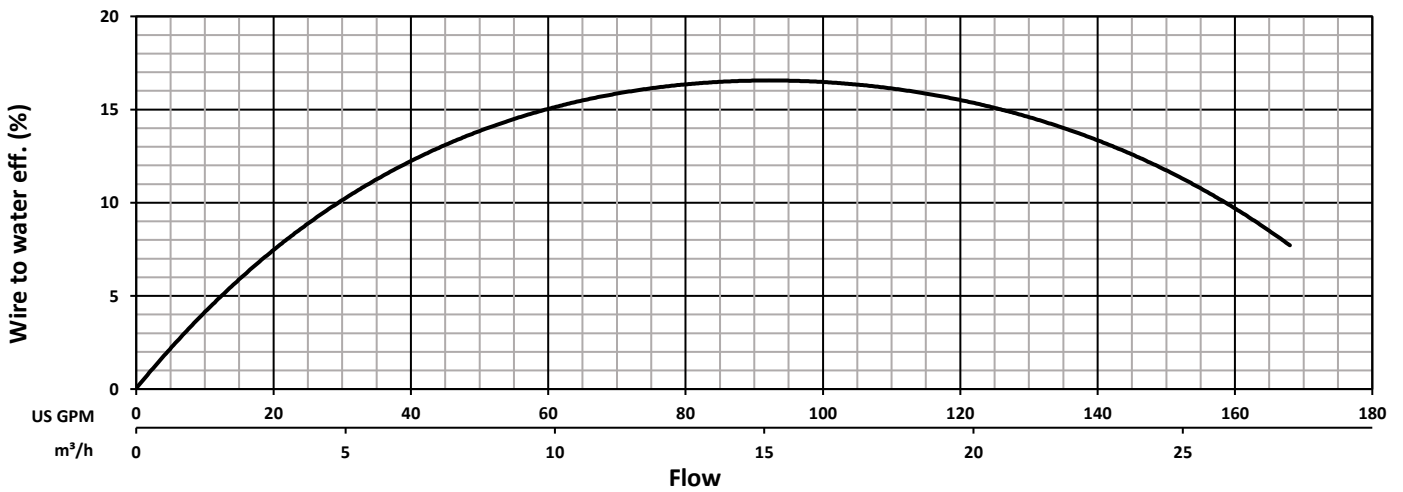
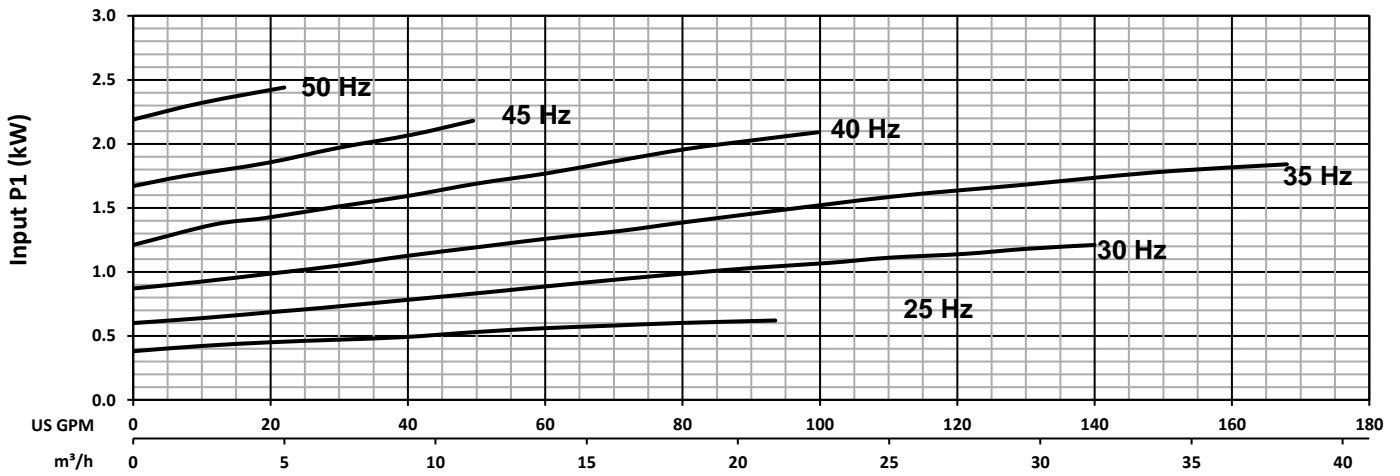
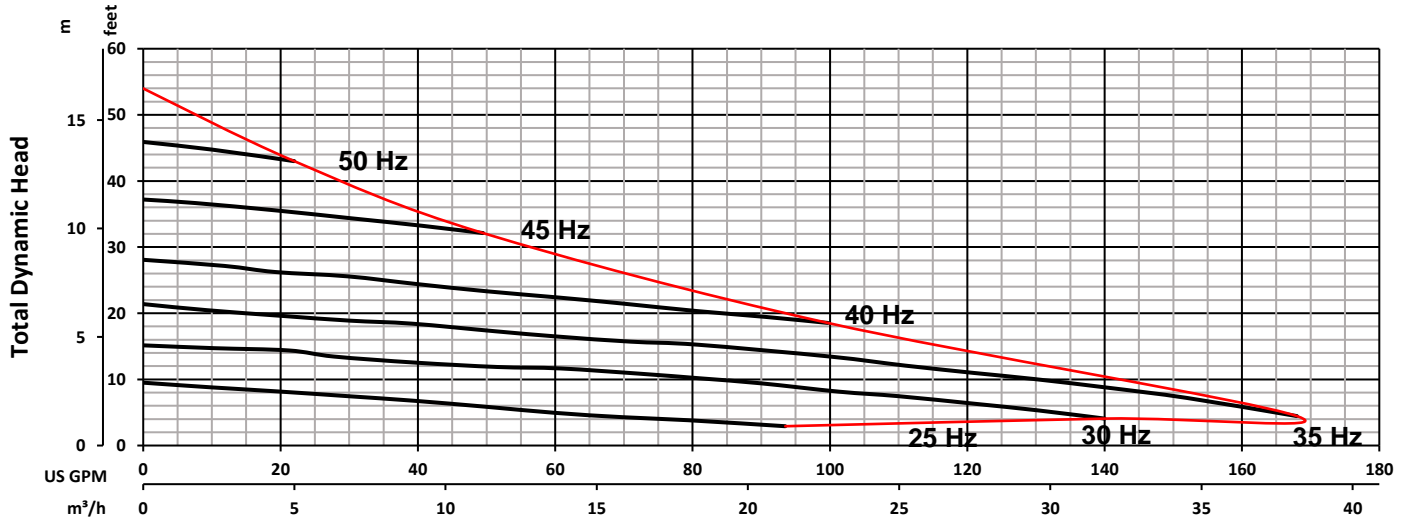

 INDUSTRIAL FLOW SOLUTIONS	PERFORMANCE CURVE OW11-2VV VX 2.2kW			DS-A50-064
	Tested with clean water Test Standard : HI 11.6 Gr 3B		Model	OW11-2VV
	Motor	2.2kW / 2.9HP	Poles	2
	Impeller	110x25x15mm	Specifications subject to change without notice	
			Rev	1
			Date	5/7/2021

PERFORMANCE CURVE OW11-2VV VX 1.5kW

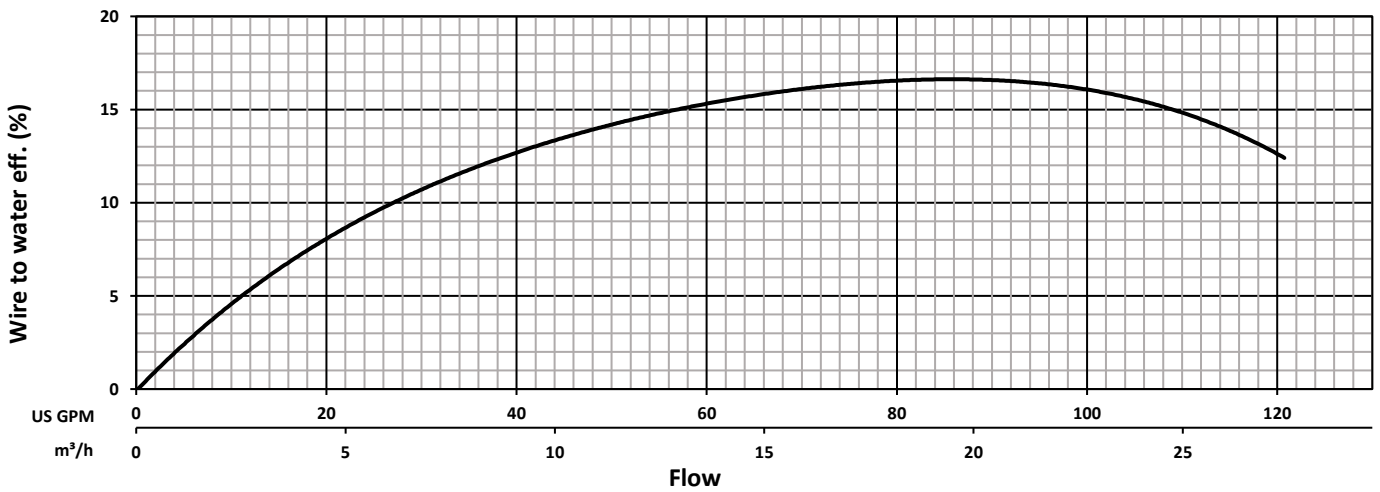
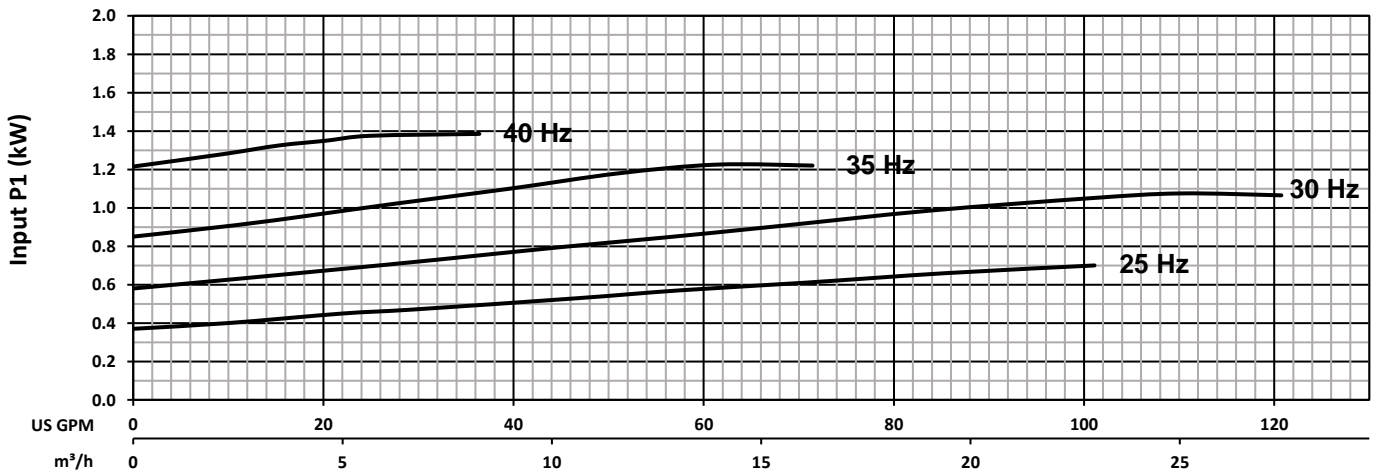
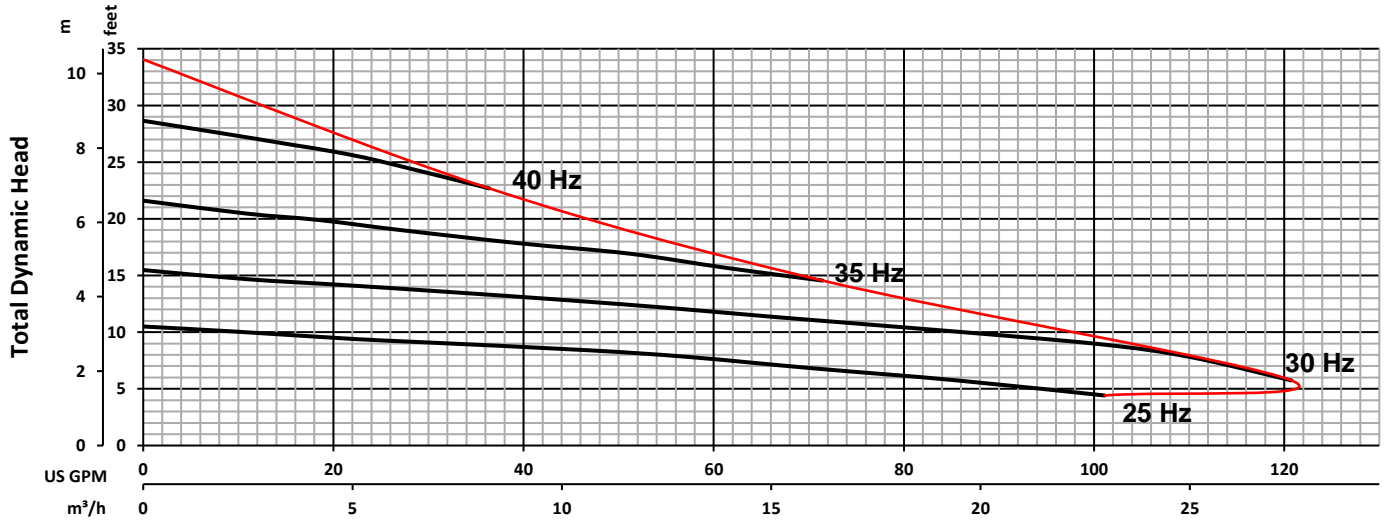

 INDUSTRIAL FLOW SOLUTIONS	PERFORMANCE CURVE OW11-2VV VX 1.5kW			DS-A50-001
	Tested with clean water Test Standard : HI 11.6 Gr 3B		Model	OW11-2VV
			Motor	1.5kW / 2HP
	Tested with clean water Test Standard : HI 11.6 Gr 3B		Impeller	110x25x15mm

Rev 1 IT
Date 4/23/2021