

**DESIGN / CONSTRUCTION**

Body	304L SS
External Hardware	304L SS
Gaskets	Buna-N
Motor Body	Cast Iron
Shaft Seal	Single Mechanical Seal
Impeller	T2,T4,S4 Impeller
Maximum Solid Size ϕ	8" (200mm)

MOTOR SPECIFICATIONS

Motor Design	6-Pole, 3-Phase Squirrel-Cage Motor 50Hz/60Hz
Motor Type	TEFC, IP67
Insulation Class	Class F
Motor Protection	Protected by VFD
Service Factor	1.15
Maximum Ambient Temp.	104°F (40°C)
Voltage Tolerance	±10%

MOTOR DATA

Rated Power	230V FLA	460V FLA	575V FLA	Weight *
15kW / 20.1HP	--	31	24.8	2160lb (982kg)
18.5kW / 24.8HP	--	36	28.8	2178lb (990kg)
22kW / 29.5HP	--	43	34.4	2222lb (1010kg)
30kW / 40.2HP	--	56	44.8	2838lb (1290kg)
37kW / 49.6HP	--	69	55.2	3234lb (1470kg)
45kW / 60.3HP	--	82	65.6	3806lb (1730kg)
55kW / 73.7HP	--	101	80.8	4136lb (1880kg)
75kW / 100HP	--	121.7	97.4	4740lb (2150kg)

DIMENSIONS (largest motor)

Inlet	16" ANSI 150#
Outlet	12" ANSI 150#
H1	27.2" (691mm)
H2	33.75" (857mm)
L	69.7" (1771mm)
P	67.3" (1710mm)

* Total weight of unit

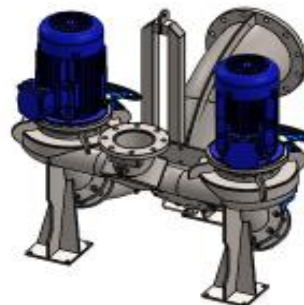
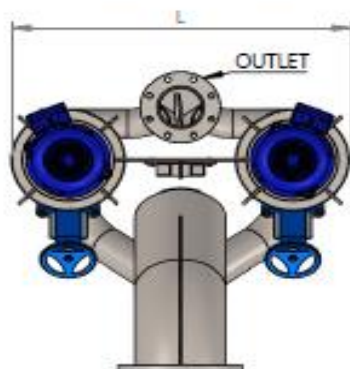
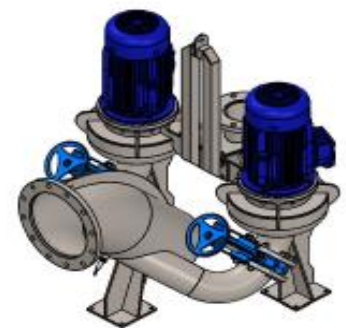
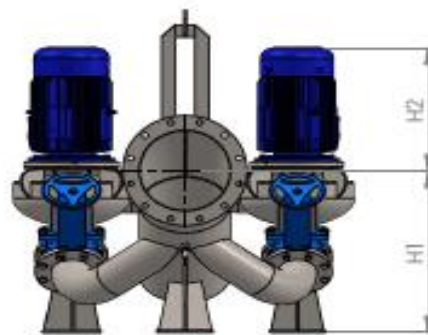
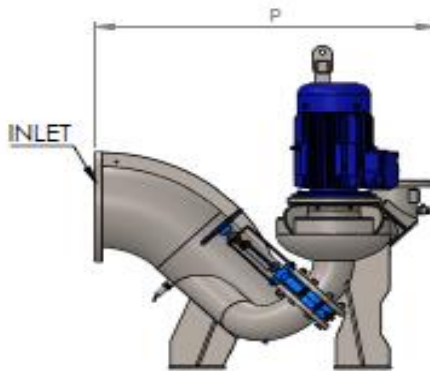

Specifications subject to change without notice

Do not use for construction purposes

PERFORMANCE CURVE OW201-6VV S4 30kW

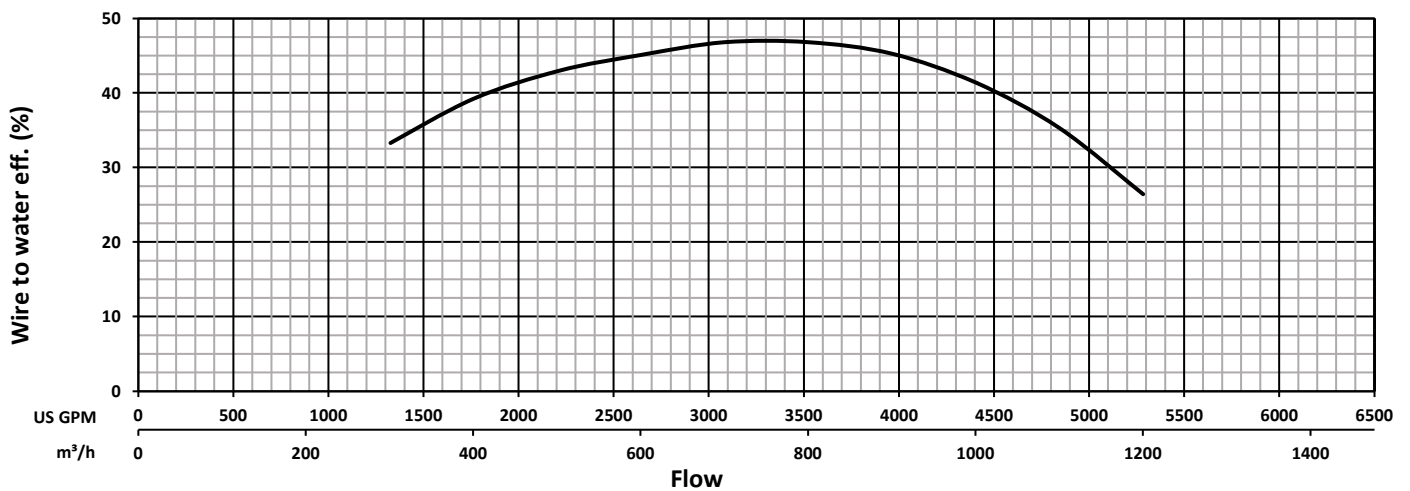
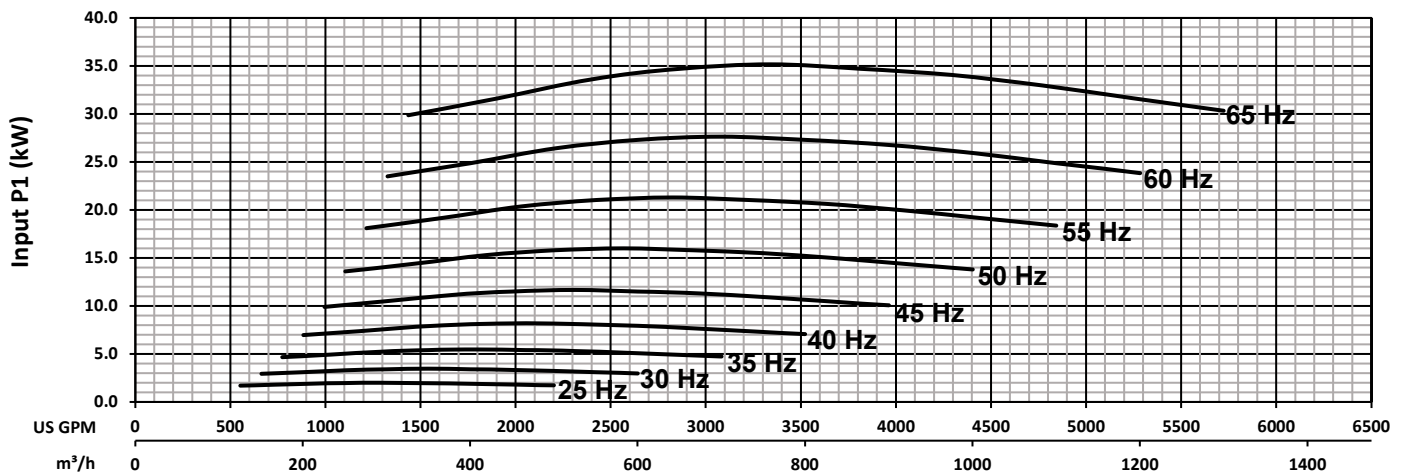
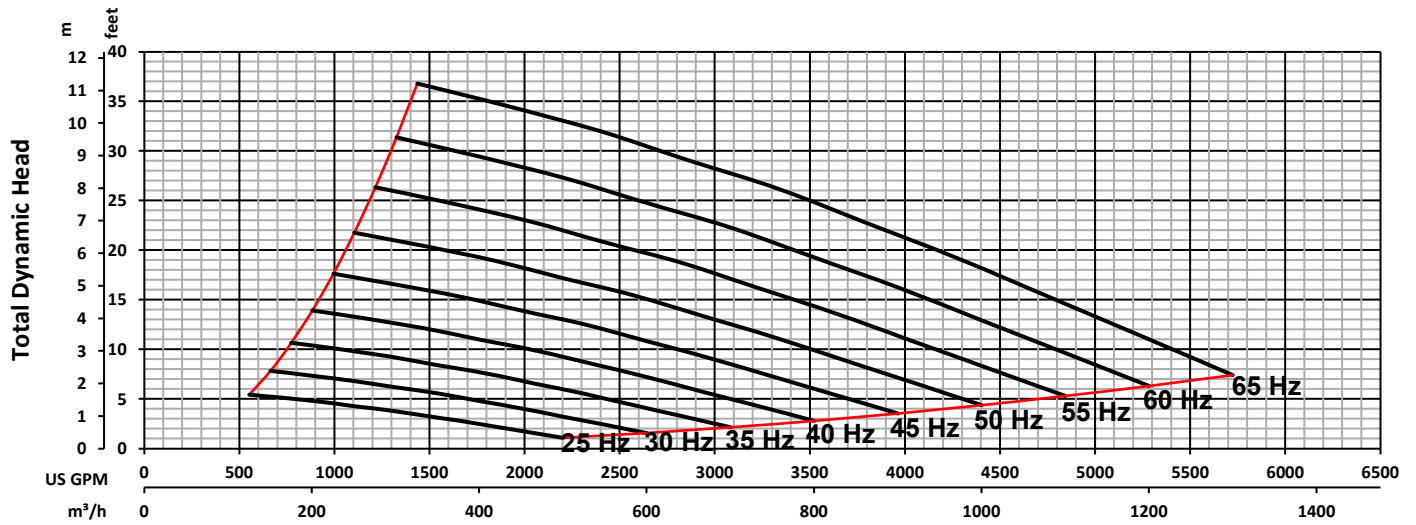

 INDUSTRIAL FLOW SOLUTIONS	PERFORMANCE CURVE OW201-6VV S4 30kW			DS-A50-238	
	Tested with clean water Test Standard : HI 11.6 Gr 3B		Model	OW201 30kW	
			Motor	30kW / 40.2HP	Poles 6
	Impeller	330mm	Specifications subject to change without notice		
		Rev	--	SCID	
		Date	6/25/2021		

PERFORMANCE CURVE OW201-6VV T4 45kW

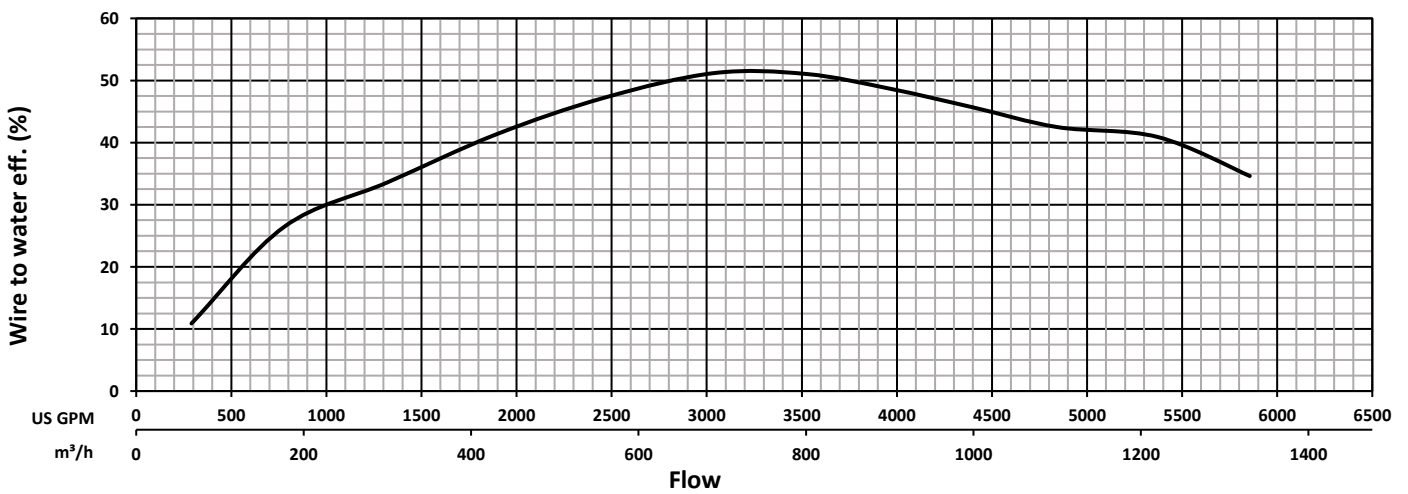
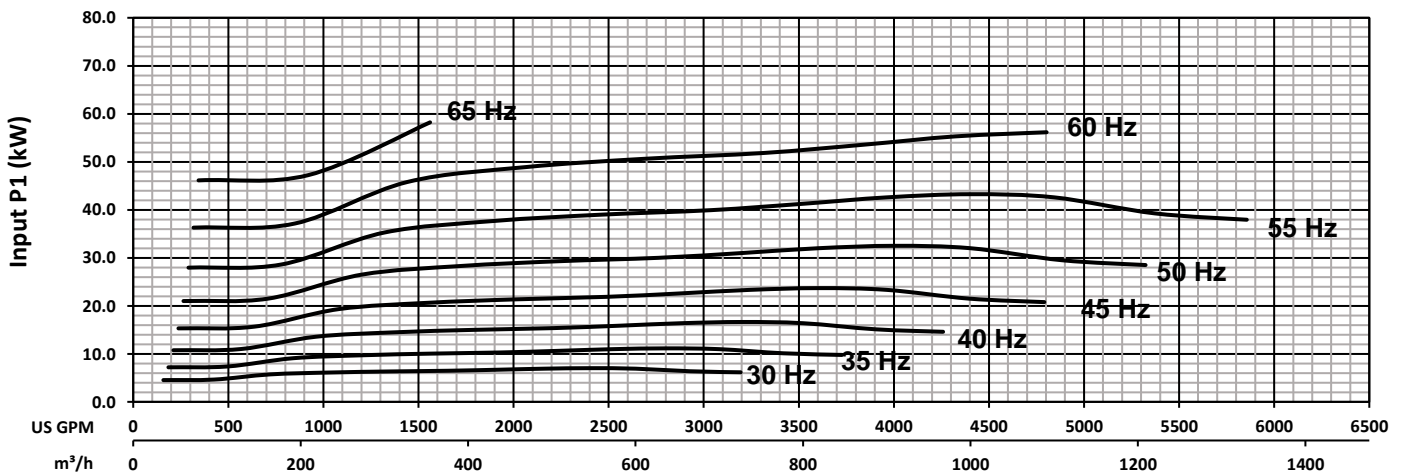
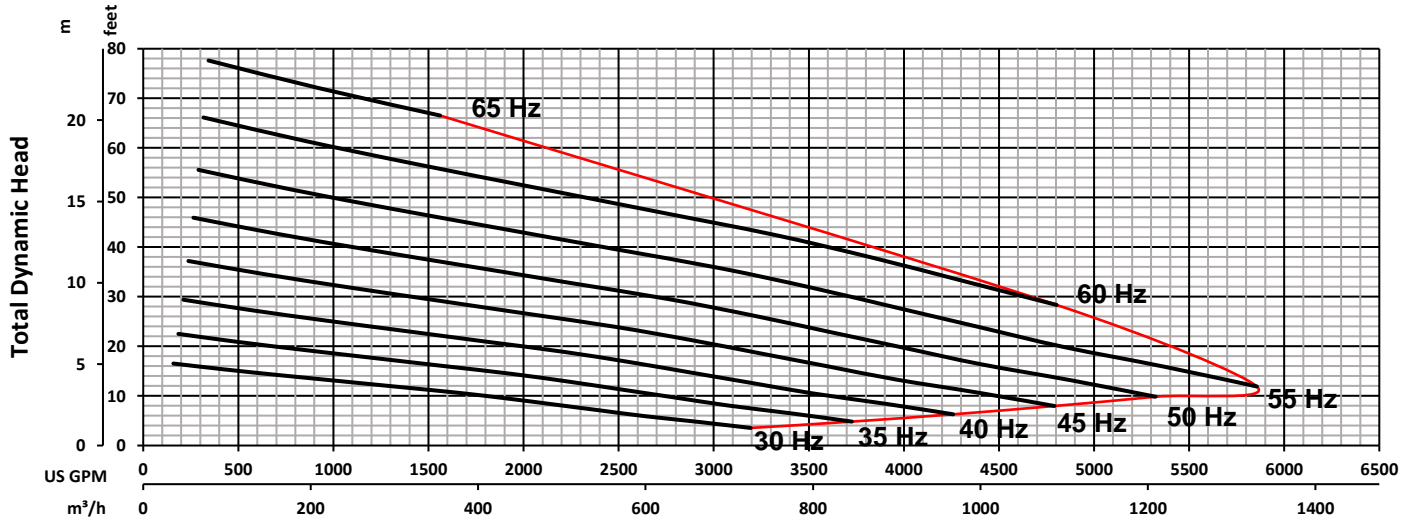

 INDUSTRIAL FLOW SOLUTIONS	PERFORMANCE CURVE OW201-6VV T4 45kW			DS-A50-118
	Tested with clean water Test Standard : HI 11.6 Gr 3B		Model	OW201-6VV
			Motor	45kW / 60.3HP Poles 6
			Impeller	400mm

PERFORMANCE CURVE OW201-6VV S4 22kW

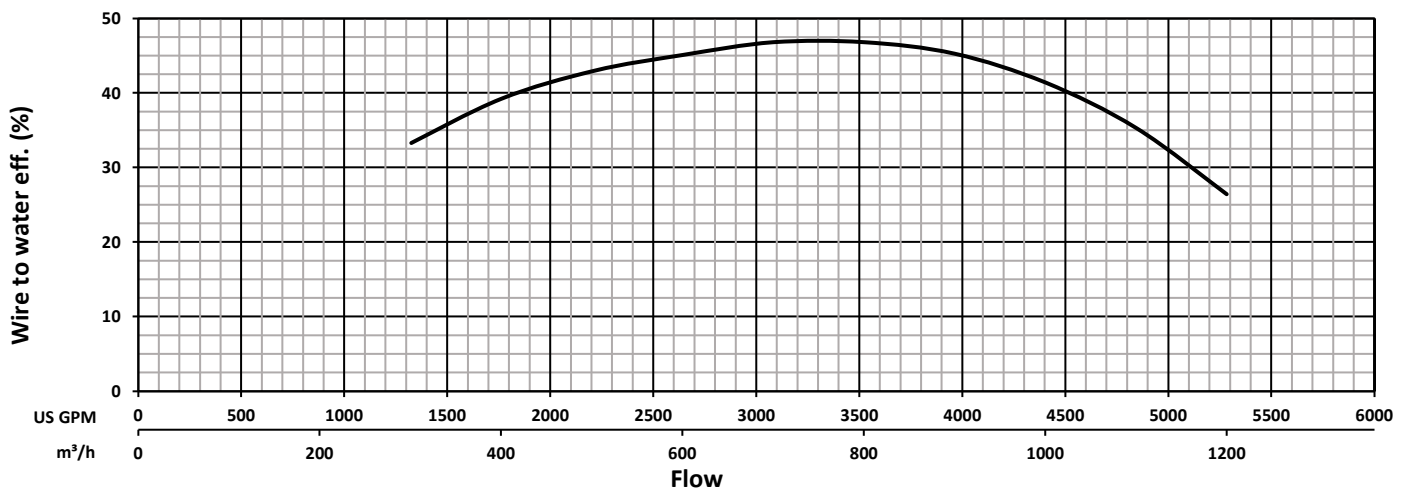
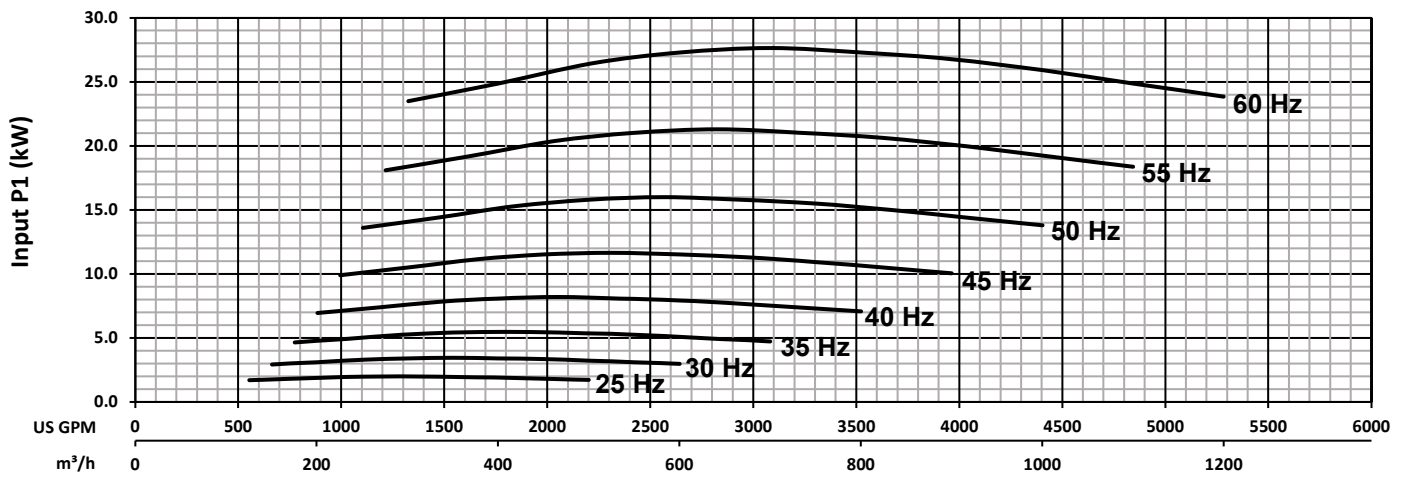
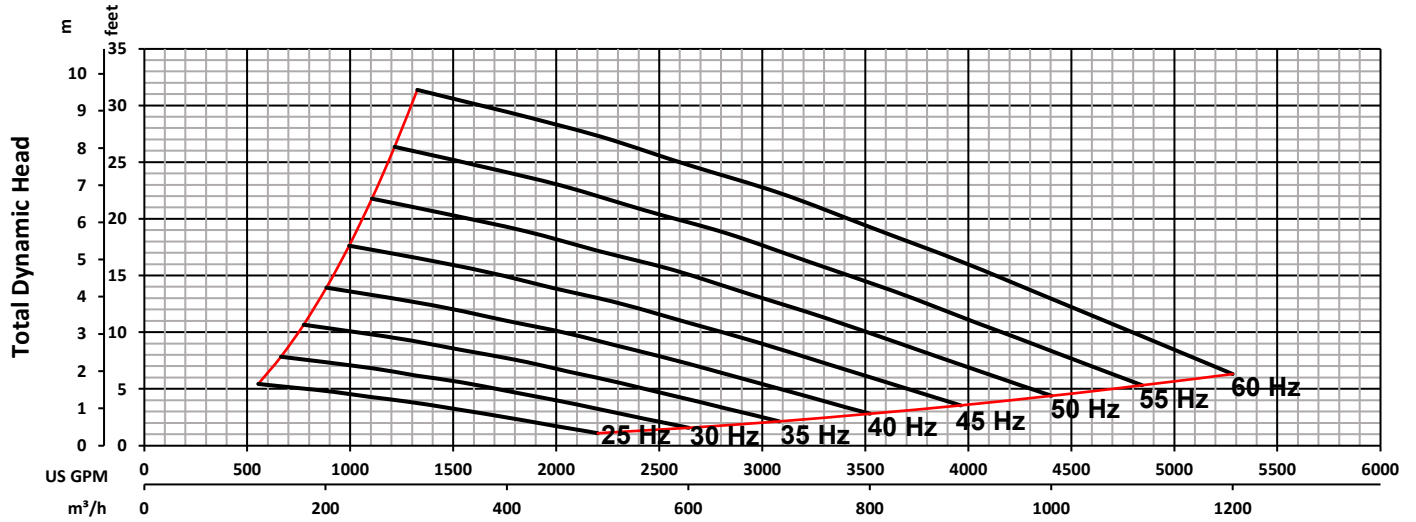

 INDUSTRIAL FLOW SOLUTIONS	PERFORMANCE CURVE OW201-6VV S4 22kW			DS-A50-071	
	Tested with clean water Test Standard : HI 11.6 Gr 3B		Model	OW201 22kW	
			Motor	22kW / 29.5HP	Poles 6
	Impeller	330mm	Specifications subject to change without notice		Rev 2 SCID

PERFORMANCE CURVE OW201-6VV S4 18.5kW

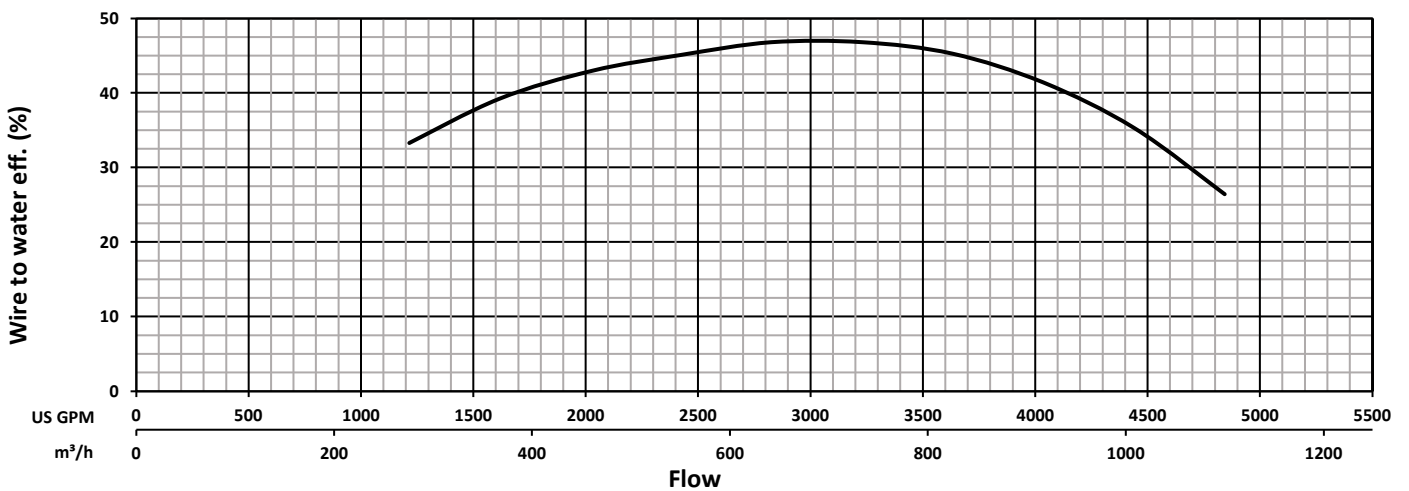
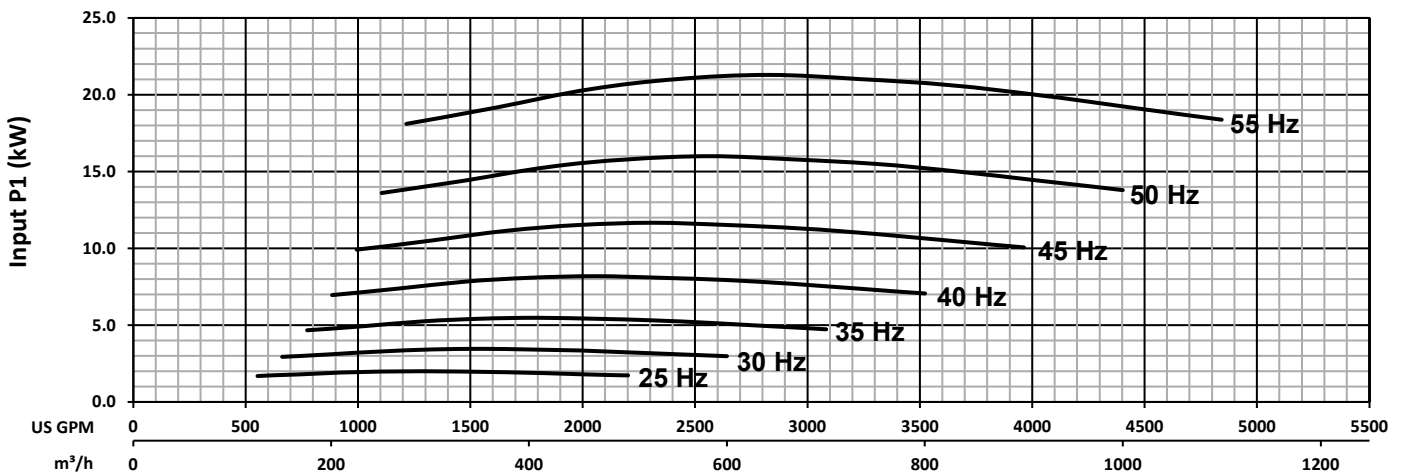
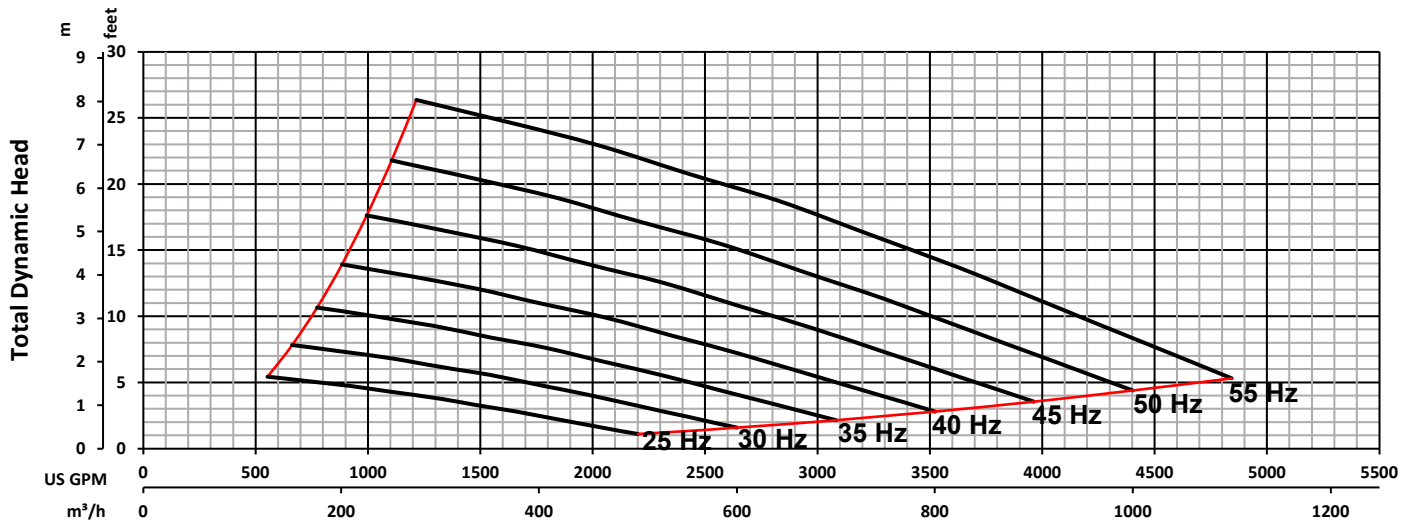

 INDUSTRIAL FLOW SOLUTIONS	PERFORMANCE CURVE OW201-6VV S4 18.5kW			DS-A50-071	
	Tested with clean water Test Standard : HI 11.6 Gr 3B		Model	OW201 18.5kW	Rev 2 SCID
			Motor	18.5kW / 24.8HP	Poles 6
	Impeller	330mm		Specifications subject to change without notice	

PERFORMANCE CURVE OW201-6VV S4 15kW

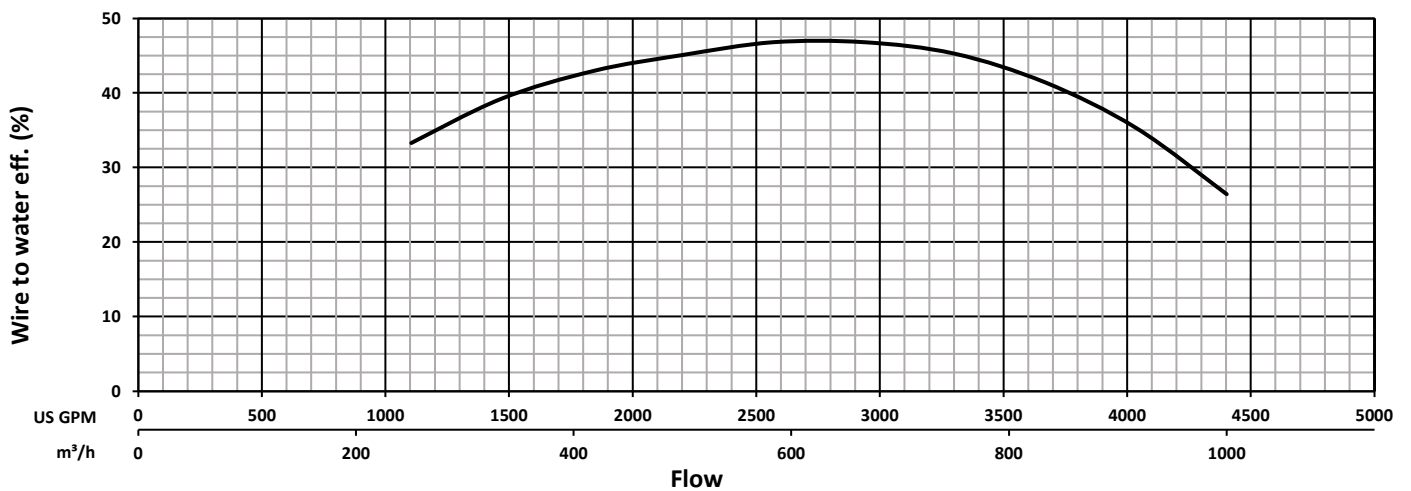
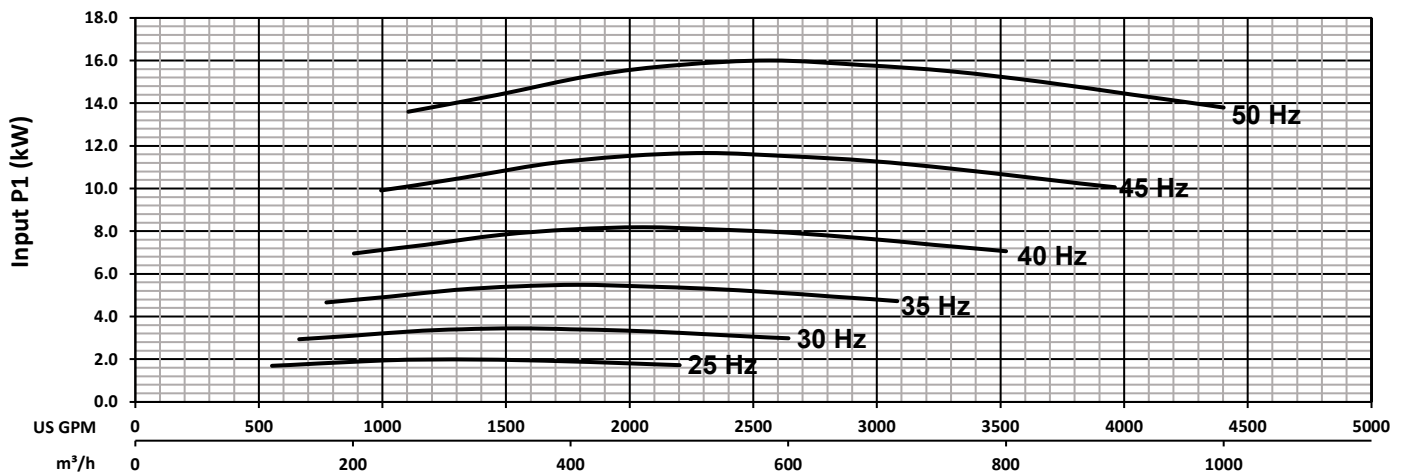
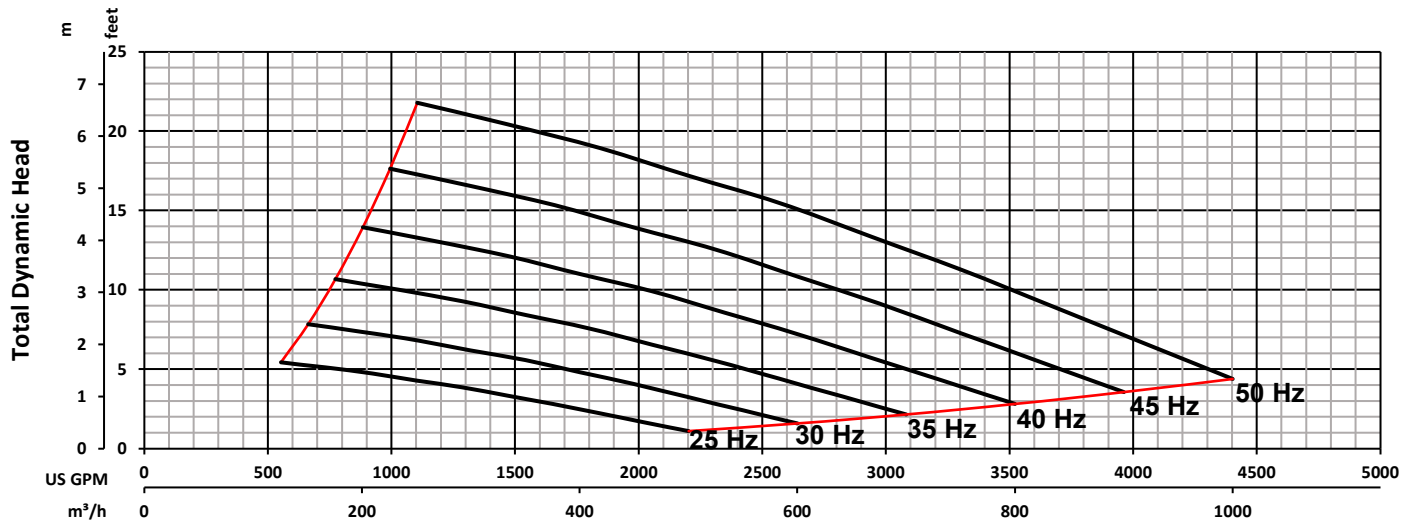

 INDUSTRIAL FLOW SOLUTIONS	PERFORMANCE CURVE OW201-6VV S4 15kW			DS-A50-072	
	Tested with clean water Test Standard : HI 11.6 Gr 3B		Model	OW201 15kW	
			Motor	15kW / 20.1HP	Poles 6
	Impeller	330mm	Specifications subject to change without notice		
				Rev 2	SCID
				Date 6/25/2021	