

DESIGN / CONSTRUCTION

| | |
|----------------------------------|---|
| Overwatch Body | 304L SS |
| External Hardware | 304L SS |
| Gaskets | Buna-N |
| Motor Body | Cast Iron |
| Shaft Seal | Single Mechanical Seal |
| Impeller | Vortex Impeller Standard, (DIPCUT® or Channel optional) |
| Maximum Solid Size \varnothing | 3.0" (80mm) |

MOTOR SPECIFICATIONS

| | |
|-----------------------|---|
| Motor Design | 4-Pole, 3-Phase Squirrel-Cage Motor 50Hz/60Hz |
| Motor Type | TEFC, IP67 |
| Insulation Class | Class F |
| Motor Protection | Protected by VFD |
| Service Factor | 1.15 |
| Maximum Ambient Temp. | 104°F (40°C) |
| Voltage Tolerance | ±10% |

MOTOR DATA

| Rated Power | 230V FLA | 460V FLA | 575V FLA | Weight * |
|----------------|----------|----------|----------|---------------|
| 5.5kW / 7.4HP | 21.6 | 10.8 | 8.6 | 419lb (190kg) |
| 7.5kW / 10.1HP | 29 | 14.5 | 11.6 | 520lb (236kg) |

DIMENSIONS (largest motor)

| | |
|--------|---------------|
| Inlet | 6" ANSI 150# |
| Outlet | 4" ANSI 150# |
| H1 | 14.7" (374mm) |
| H2 | 17.5" (445mm) |
| L | 33.6" (854mm) |
| P | 29.5" (750mm) |

* Total weight of unit

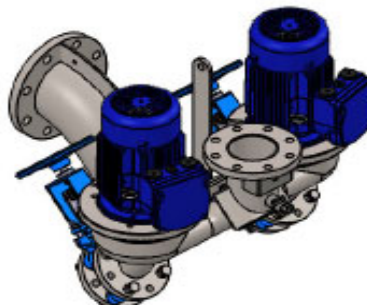
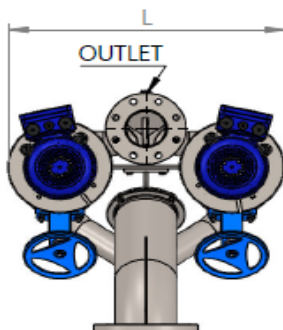
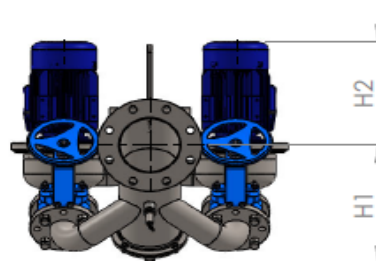
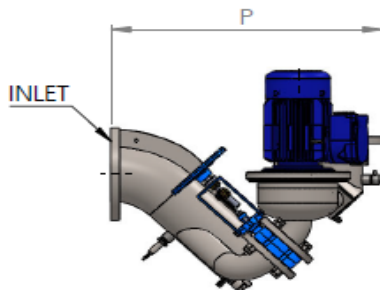

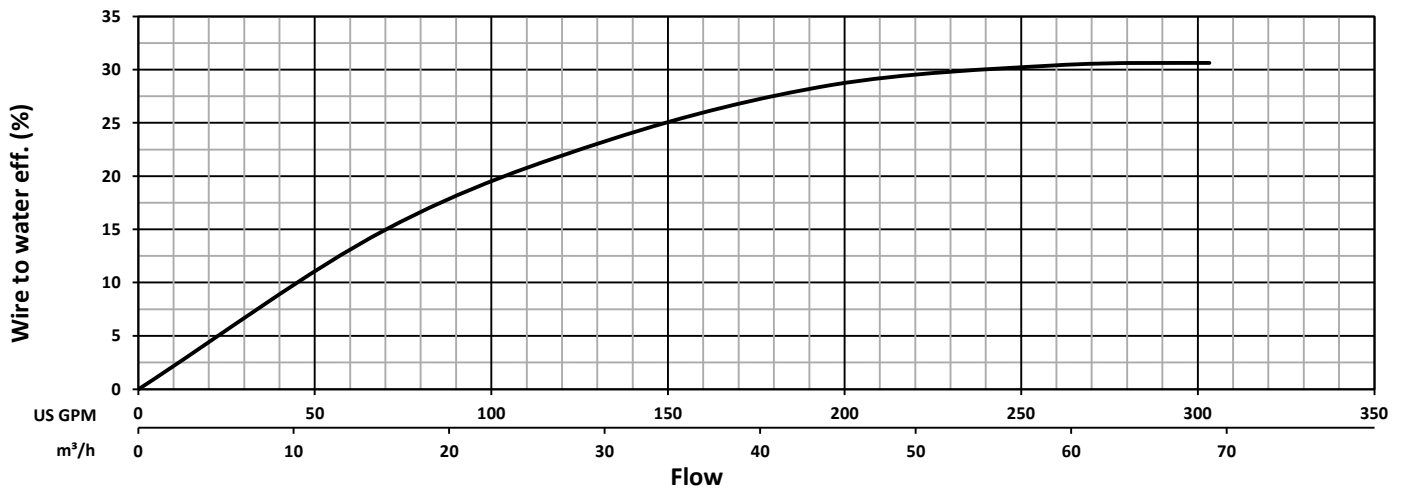
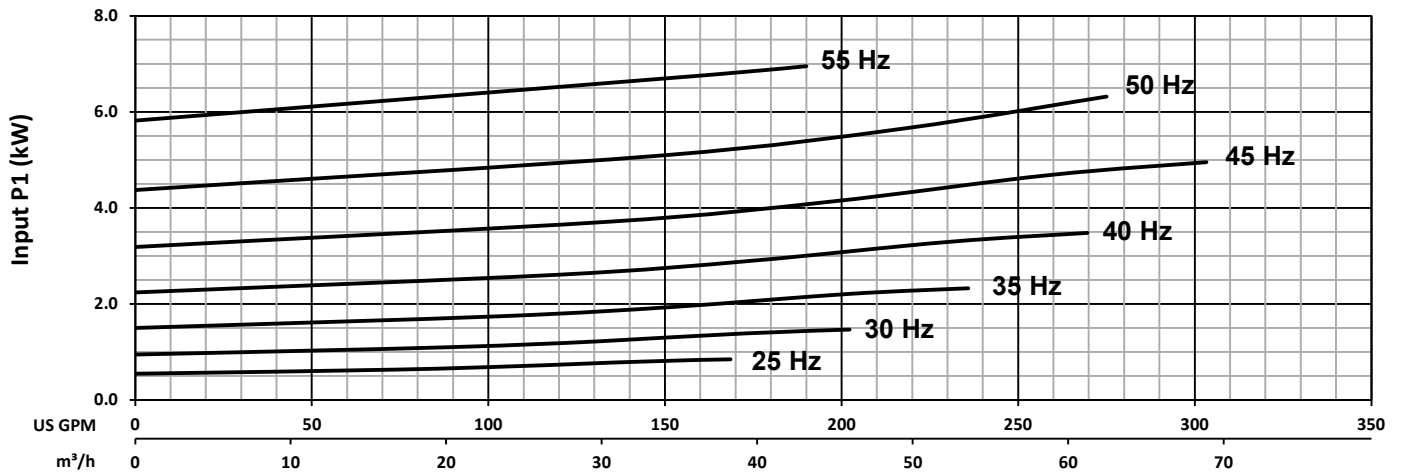
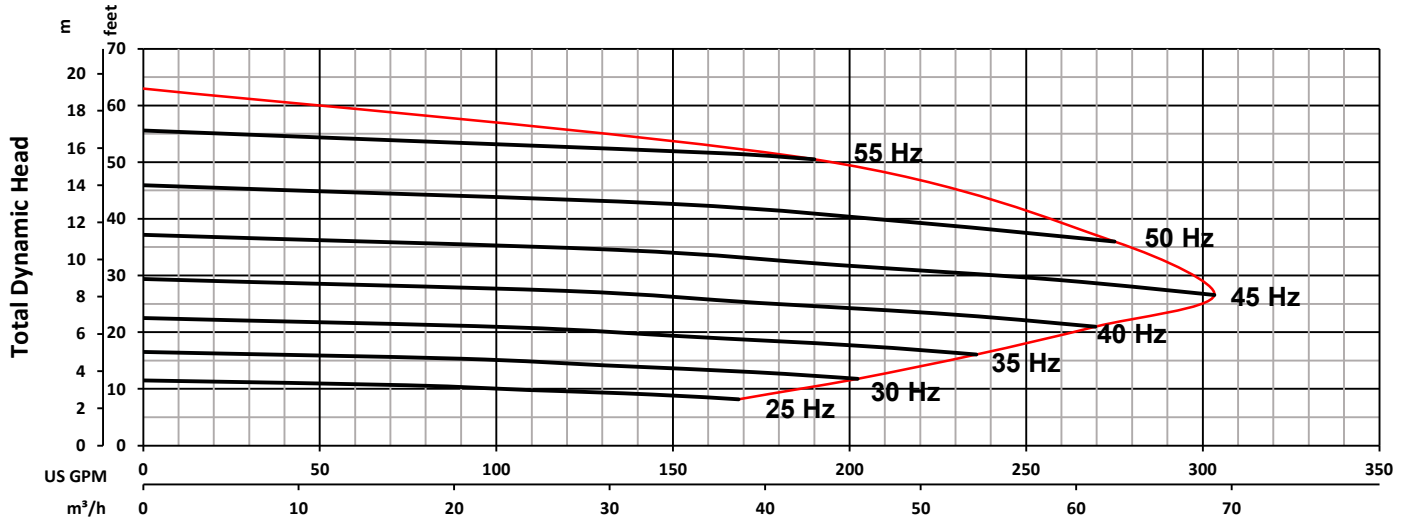

PERFORMANCE CURVE OW61-4VV VX 5.5kW

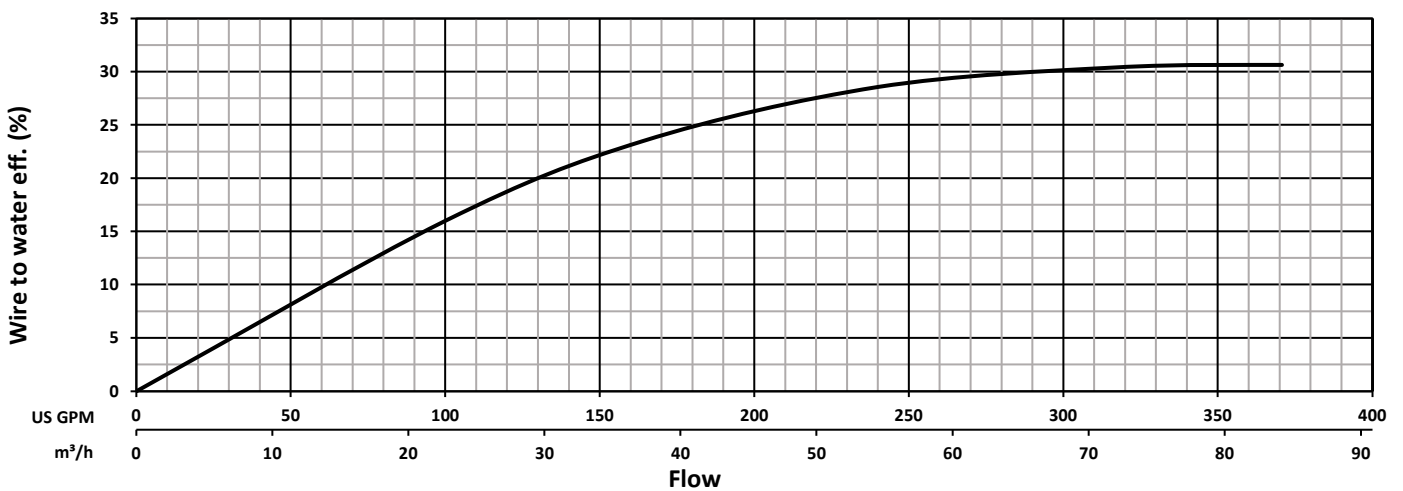
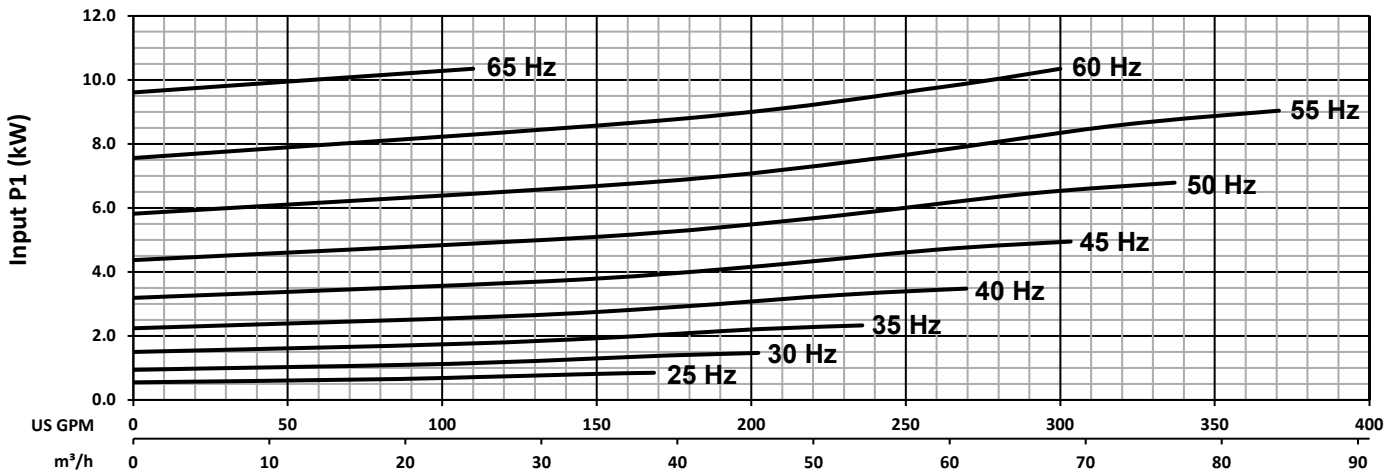
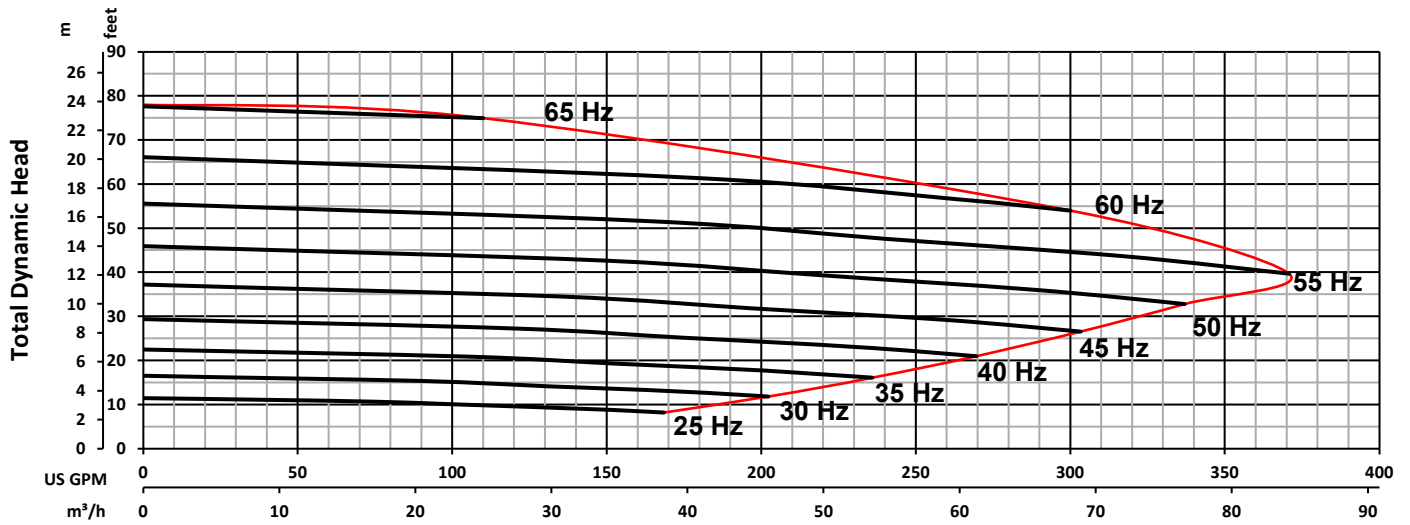

| | | | | | | |
|---|--|-------------------|--------------|-------------------|----------------|------------|
|  INDUSTRIAL FLOW SOLUTIONS | PERFORMANCE CURVE OW61-4VV VX 5.5kW | | | DS-A50-178 | | |
| | Tested with clean water Test Standard : HI 11.6 Gr 3B | | Model | OW61-4VV | | Rev 1 SCID |
| | | | Motor | 5.5kW / 7.4HP | Poles | 4 |
| | | Impeller Ø | 200x40x20mm | | Date 3/16/2021 | |
| Specifications subject to change without notice | | | | | | |

PERFORMANCE CURVE OW61-4VV VX 7.5kW



| | | | | | |
|---|--|--|-------------------|-----------------------|---|
|  INDUSTRIAL FLOW SOLUTIONS | PERFORMANCE CURVE OW61-4VV VX 7.5kW | | | DS-A50-168 | |
| | Tested with clean water Test Standard : HI 11.6 Gr 3B | | Model | OW61-4VV | |
| | | | Motor | 7.5kW / 10.1HP | Poles 4 |
| | | | Impeller Ø | 200x40x20mm | Specifications subject to change without notice |
| | | | | Rev 1 | SCID |
| | | | | Date 3/16/2021 | |