

# SECONDARY OIL CONTAINMENT SOLUTIONS

SPILL PREVENTION, CONTROL & COUNTERMEASURE



# EARLY DETECTION OF AN OIL SPILL IS CRITICAL TO PREVENTING HARMFUL POLLUTION AND ENVIRONMENTAL CONTAMINATION.

Secondary Oil Containment Solutions must be designed to provide immediate detection of an oil spill to avoid the threat of chemical exposure to human and animal life and destruction of vegetation, as well as service disruption and system downtime. At the same time, companies need to take into consideration the liability and fines associated with non-conformity and damage associated with an oil spill.

## ■ THE OIL MINDER® SOLUTION

Oil Minder® is a pump and control system allowing water to be automatically pumped without danger of ejecting potentially harmful hydrocarbons or oily substances into sewers, rivers, and waterways.

Oil Minder sensing products and controls minimize environmental and safety risks.

**Oil Minder® provides solutions across a wide-range of industries:**

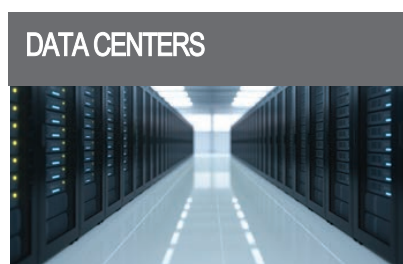

Industrial Flow Solutions™, is committed to providing customized solutions that redefine expectations in the market. For more than 20 years, Oil Minder® solutions have been operating reliably in the field with over 25,000 systems installed.

# HOW IT WORKS

The real differentiator for Oil Minder® is how the control panel interacts with the oil probe and pump to ensure proper performance, redefining expectations for operations and maintenance. Measuring conductivity in a liquid, Oil Minder has proven reliable to differentiate oil and water. Self-cleaning, conductivity probes are maintenance-free compared to optical sensors that attract contaminants. The result is a newfound level of safety, maintenance practices, condition monitoring, and protection against liability.

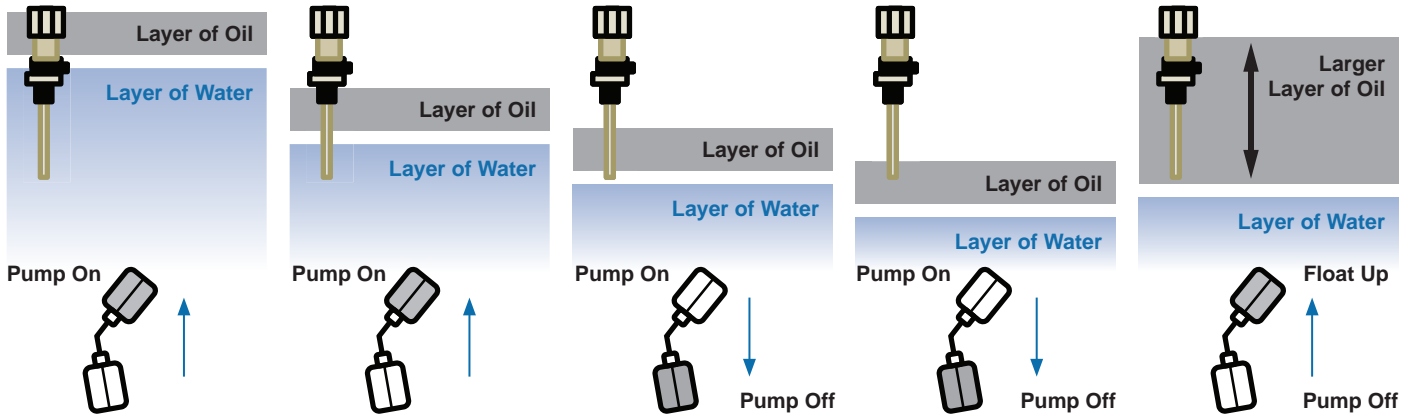

Pump goes ON with water in contact with sensor probe.

Pump continues to pump down water.

Pump continues to run, pumping water only until:

- water level drops below tip of sensor probe OR
- only oil is in contact with the sensor probe, eliminating electrical conductivity.

Pump shuts off before oil is pumped, leaving approximately 3" of liquid in bottom sump.

Oil levels in the sump cause the sensor probe to switch the pump off (containing oil). If the water level in the sump increases, then the oil will rise above the oil sensing probe. This will cause the pump to turn back on and function in a normal manner until water is pumped down. Oil will, once again, come in contact with the probe and the pump will stop.

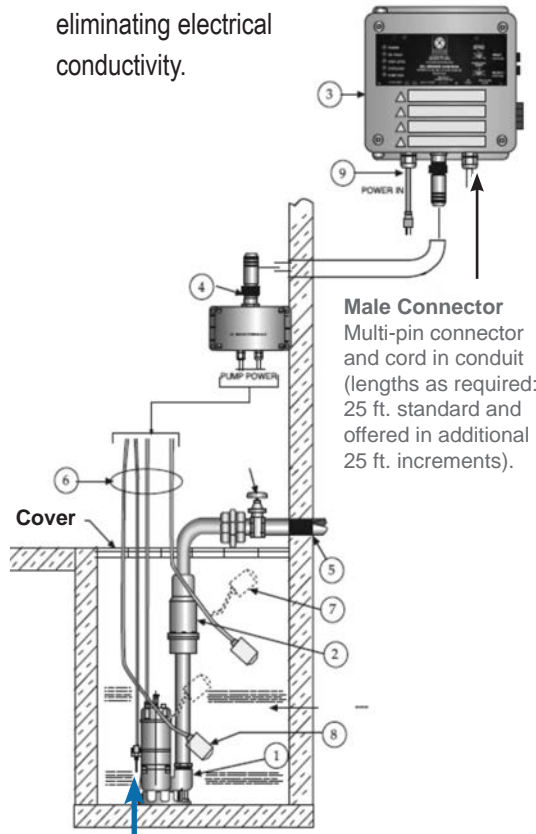
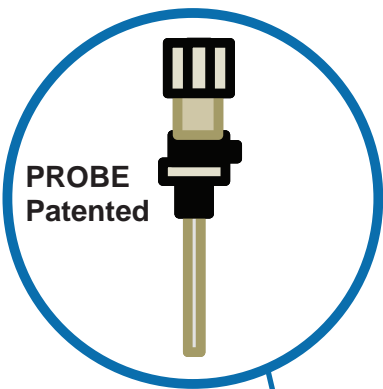

**Male Connector**  
Multi-pin connector and cord in conduit (lengths as required: 25 ft. standard and offered in additional 25 ft. increments).

Audible/visual alarms accompany pump activity. This ensures Oil Minder acts as an approved alarm system as specified in ASME 17.1.

## KEY ATTRIBUTES

- Long Term Durability and Reliability
  - NEMA 4X weather-tight corrosion resistant polycarbonate enclosures
  - Stainless Steel sensor probe with patented electronic technology repelling dirt contamination
- Ease of Installation, Maintenance, and Increased Operational Safety
  - Single direct plug-in power source for operation of entire system
  - Alarms, lights, silence switch, and remote monitoring circuit for oil, high liquid, and high current conditions
  - LED Indicator lights for oil spill, power, high liquid level, overload and pump run
  - Solid state “push to test” switch conveniently performs all pump and control diagnostic tests
  - Complete factory assembly and testing ensures quality of entire pumps and control system
- May be combined with a variety of different pumps & valves including those that can handle solids.

## EARLY DETECTION ELIMINATES POLLUTION

Early warning is an essential element in risk prevention. Designed to detect the smallest sheen of oil, Oil Minder uses patented conductive sensing technology and communication protocols to provide a very early warning notification. Key personnel are notified immediately of a possible dangerous hazard enabling advance actions. Oil Minder allows for quick and accurate development of a countermeasure plan and provides the following communication protocols:

- Pump Failure to Flow
- High Water Alarm
- Pump Overload
- Float Failures
- Oil Fault
- Pump Run Status
- Pump Failure to Start

Equipped with state-of-the-art communication protocols for effectively transmitting live signals and alarms to remote monitoring systems.

