

G2 Series Submersible Grinder Pumps

Engineered for high performance in demanding environments, the G2 Series pumps are equipped with a built-in macerator that efficiently breaks down solids in wastewater. With versatile, long-lasting performance, they are ideal for domestic and industrial sewage, liquids with suspended solids, and applications requiring high pressure (head).

FEATURES

- **Built-in Macerator:** Radial and axial cutting action for solid waste breakdown
- **Grinding System:** Hardened steel blades for maximal cutting efficiency
- **Seal Minder® Probe:** Standard on all series providing enhanced monitoring for seal condition
- **Thermal Protection:** Supplied with 2 thermal switches in the motor windings to protect against overheating
- **Cable Gland:** Made of stainless steel AISI 316, standard across all models

BENEFITS

- **Superior Waste Handling:** The integrated macerator allows for effective waste transport through narrow pipes
- **Long-Term Performance:** Hardened steel blades ensure high efficiency and durability
- **Dependable Operation:** Mechanical seals & Seal Minder® probe guarantee leak-free operation and extended service life
- **Durable Design:** Stainless steel cable gland ensures a robust and long-lasting system



Motor Casing

Motor Shaft & Rotor

Electric Motor

Flange Bearing Support

Upper Mechanical Seal

Lower Mechanical Seal

Volute

Closing Plate

Impeller

Grinding System

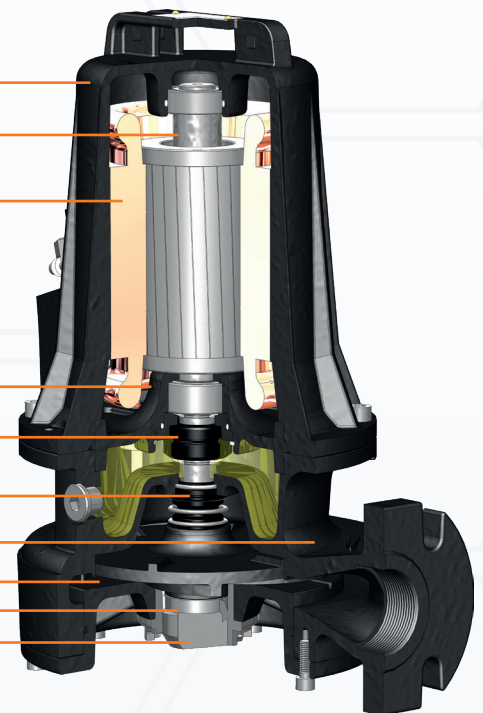

SPECIFICATIONS

All models available in 460V, 3-ph, 60-hz.

Model	Motor Rating	Full Load Amps	Discharge	Max. Head	Max. Flow
G2-19	2.5 HP 1.9 kW	4.1	2" NPS-F DN32-PN6	99 ft 30.2 m	71 GPM 269 LPM
G2-22	3 HP 2.2 kW	4.8	2" NPS-F DN32-PN6	131 ft 39.9 m	70 GPM 265 LPM
G2-41	5.5 HP 4.1 kW	8.3	2" NPS-F DN50-PN10	125 ft 38.1 m	71 GPM 269 LPM
G2-56	8.5 HP 6.3 kW	12.2	2" NPS-F DN50-PN10	161 ft 49.1 m	108 GPM 409 LPM
G2-75	10.5 HP 7.8 kW	14.7	2" NPS-F DN50-PN10	195 ft 59.4 m	102 GPM 386 LPM
G2-97	13 HP 9.7 kW	18.2	2" NPS-F DN50-PN10	226 ft 68.9 m	95 GPM 360 LPM

PERFORMANCE CURVES

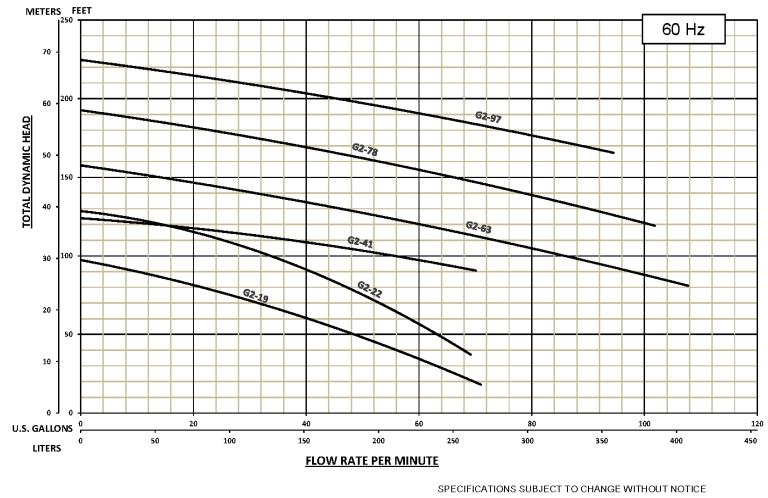

DIMENSIONS

Displayed in mm

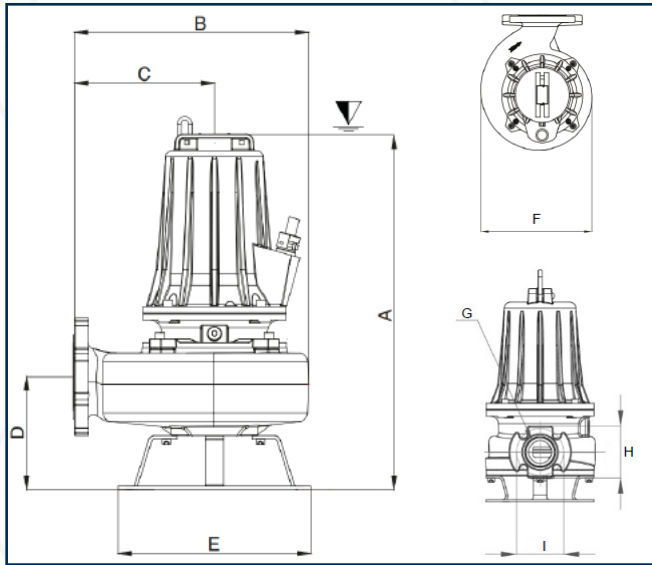

Model	A	B	C	D	E	F	G	H	I
G2-19	403	260	152	96	206	209	2" NPS-F DN32-PN6	100	90
G2-22	403	260	152	96	206	209	2" NPS-F DN32-PN6	100	90
G2-41	506	330	191	96	260	253	2" NPS-F DN50-PN10	140	125
G2-63	563	355	215	122	275	275	2" NPS-F DN50-PN10	140	125
G2-78	563	355	215	122	275	275	2" NPS-F DN50-PN10	140	125
G2-97	563	355	215	122	275	275	2" NPS-F DN50-PN10	140	125

MATERIALS

- **Grey Cast Iron:** GG25 cast iron for durable housing and impeller
- **Hardened Steel Blades:** Maximal cutting efficiency for handling solid waste
- **Stainless Steel Components:** External components like cable glands for corrosion resistance



INDUSTRIAL
FLOW
SOLUTIONS™

North America / Latin America - IFS
104 John W Murphy Drive New Haven, CT 06513 USA
(860) 631-3618 | sales@flowsolutions.com
www.flowsolutions.com