

V Series Solids Handling Pumps

Engineered for high performance in demanding environments, the V Series pumps are designed to handle sewage with suspended solids efficiently. With versatile, high-flow capabilities, they are ideal for applications such as water treatment plants, industrial facilities, farming, and sewage systems.

FEATURES

- **Vortex Impeller:** Suitable for pumping unfiltered sewage and fibrous liquids
- **Seal Minder® Probe:** Standard on all series providing enhanced monitoring for seal condition
- **Cable Gland:** Stainless steel AISI 316, standard on all models
- **Thermal Protection:** Supplied with 2 thermal switches in the motor windings to protect against overheating

BENEFITS

- **High-Performance Sewage Handling:** Vortex impellers designed for pumping sewage with solid & fibrous parts
- **Long-Term Durability:** Mechanical seals and the Seal Minder® probe ensure extended service life and reliability
- **Corrosion Resistance:** Stainless steel components guarantee long-lasting performance in harsh environments



Wastewater
Treatment Plants



Agricultural
Operations



Industrial
Facilities



Lift Stations

Chain Ring

Motor Casing

Upper Bearing

Motor Shaft & Rotor

Electric Motor

Lower Bearing

Motor Support

Upper Mechanical Seal

Lower Mechanical Seal

Volute

Impeller

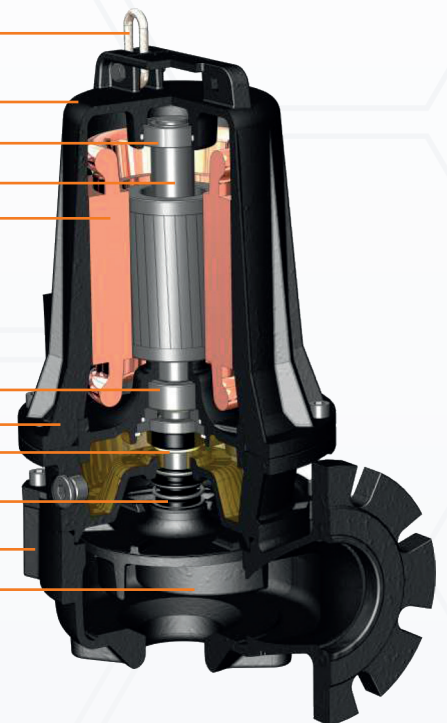

SPECIFICATIONS

All models available in 460V, 3-ph, 60-hz.

Model	Motor Rating	Full Load Amps	Discharge	Max. Head	Max. Flow	Max. Solids
V2-15	2 HP 1.5 kW	3.4	DN65- PN10	32 ft 9.8 m	179 GPM 678 LPM	2 in 50 mm
V2-22	3 HP 2.2 kW	4.8	DN65- PN10	45 ft 13.7 m	211 GPM 799 LPM	2 in 50 mm
V2-41	5.5 HP 4.1 kW	8.3	DN80- PN16	71 ft 21.6 m	285 GPM 1079 LPM	2.6 in 65 mm
V2-56	7.5 HP 5.6 kW	11	DN80- PN16	71 ft 21.6 m	391 GPM 1480 LPM	2.75 in 70 mm
V2-75	10 HP 7.5 kW	14	DN80- PN16	89 ft 27.1 m	514 GPM 1946 LPM	2.75 in 70 mm
V2-89	12 HP 8.9 kW	16.8	DN80- PN16	100 ft 30.5 m	450 GPM 1703 LPM	2.75 in 70 mm
V4-11	1.5 HP 1.1 kW	3	DN80- PN16	26 ft 7.9 m	243 GPM 920 LPM	3 in 75 mm
V4-22	3 HPW 2.2 kW	4.8	DN80- PN16	33 ft 10.1 m	348 GPM 1317 LPM	3.25 in 80 mm
V4-30	4 HP 3 kW	6.2	DN80- PN16	38 ft 11.6 m	384 GPM 1454 LPM	3.25 in 80 mm
V4-41	5.5 HP 4.1 kW	8.3	DN100- PN16	32 ft 9.8 m	584 GPM 2210 LPM	3.5 in 90 mm
V4-56	7.5 HP 5.6 kW	11	DN100- PN16	41 ft 12.5 m	720 GPM 2725 LPM	3.5 in 90 mm
V4-75	10 HP 7.5 kW	14	DN100- PN16	54 ft 16.5 m	810 GPM 3066 LPM	3.5 in 90 mm

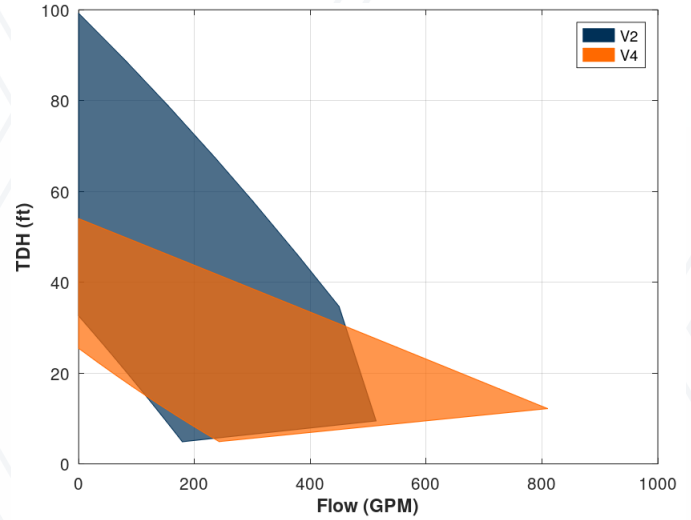

MATERIALS

- **Cast Iron Housing:** GG25 grey cast iron for robust construction
- **Vortex Impeller:** Designed for unfiltered sewage with suspended solids
- **Stainless Steel Components:** Cable glands and external components made of stainless steel for corrosion resistance

DIMENSIONS

Displayed in mm

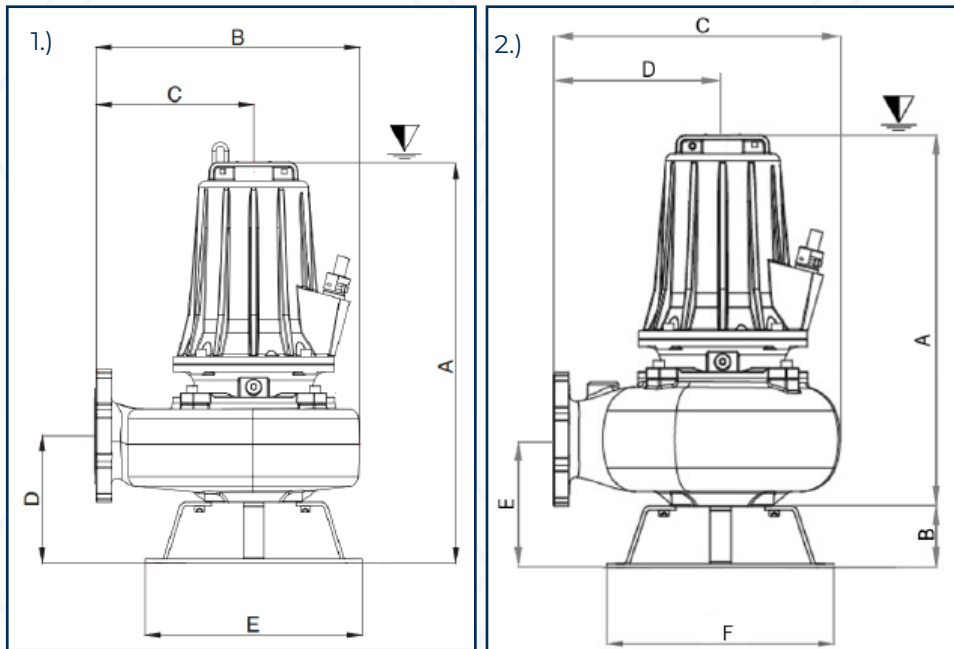

1.)

Model	A	B	C	D	E
V2-15	536	294	210	127	260
V2-22	536	294	210	127	260
V2-41	556	340	198	180	260
V2-56	610	368	198	180	320
V2-75	610	368	198	180	320
V2-89	610	368	198	180	320

2.)

Model	A	B	C	D	E	F
V4-11	399	54	323	178	100	*
V4-15	399	54	323	178	100	*
V4-22	528	85	385	228	185	322
V4-30	528	85	385	228	185	322
V4-41	609	101	470	278	212	370
V4-56	609	101	470	278	212	370
V4-75	609	101	470	278	212	370

* Built in stand



INDUSTRIAL
FLOW
SOLUTIONS™

North America / Latin America - IFS
104 John W Murphy Drive New Haven, CT 06513 USA
(860) 631-3618 | sales@flowsolutions.com
www.flowsolutions.com