



INSTALLATION, OPERATION & MAINTENANCE MANUAL

KZNMD SERIES HEAVY DUTY AGITATOR TOP DISCHARGE Electric Submersible Pumps

CAST IRON

Three Phase

208V, 230V, 460V, & 575V

KZN37MD
KZN55MD

KZN55HMD

Three Phase

230V, 460V & 575V

KZN75MD
KZN110HMD

KZN110MD

Three Phase

460V & 575V

KZN150MD
KZN150LMD

KZN220MD
KZN220LMD

Read this manual carefully before installing, operating or servicing these pump models. Observe all safety information. Failure to comply with instructions may result in personal injury and/or property damage. Please retain these instructions.

TABLE OF CONTENTS

INTRODUCTION	4
HSAFETY	5
INSPECTION	6
PRE-INSTALLATION INSPECTION	6
OIL FILL QUANTITY/TYPE	6
PUMP INSTALLATION	7
POSITIONING THE PUMP	7
PUMP ROTATION.....	7
PUMP OPERATION	9
TYPICAL MANUAL DEWATERING INSTALLATION	9
STOPPING.....	9
TYPICAL AUTOMATIC DEWATERING INSTALLATION.....	10
STOPPING.....	11
INTENDED METHODS OF CONNECTION	12
THREE PHASE WIRING INSTRUCTION.....	12
TROUBLE SHOOTING	14
PUMP WILL NOT RUN.....	14
PUMP RUNS BUT DOES NOT DELIVER RATED CAPACITY	14
SERVICING YOUR SUBMERSIBLE PUMP.....	14
MAINTAINING YOUR PUMP.....	14
CHANGING SEAL OIL.....	15
CHANGING SEALS*	16
EXPLODED VIEW OF KZN37, 55, 55R, 55CH, 55CHR, 75, 75R	17
EXPLODED VIEW OF KZN110, 110R, 110H, 110HR, 150, 150R, 150L, 150LR.....	18
EXPLODED VIEW OF KZN220, 220R, 220L, 220LR	19
KZN SERIES PARTS LIST	20
KZN R PARTS LIST.....	22
THREE PHASE WIRING DIAGRAMS	24
230V (5 LEAD).....	24
MODELS KZN37, 37R, 55, 55CH, 55R, 55CHR, 75, 75R, 110, 110H, 110R, 110HR.....	24
460V (5 LEAD).....	25
MODELS KZN37, 37R, 55, 55R, 55CHR, 75, 75R, 110, 110H, 110HR, 150, 150L, 150L, 150LR, 150R, 220, 220L, 220LR, 220R	25
575V (5 LEAD).....	26
MODELS KZN37, 37R, 55, 55R, 55CHR, 75, 75R, 110, 110H, 110HR, 150, 150L, 150L, 150LR, 150R, 220, 220L, 220LR, 220R	26
SEAL MINDER®.....	27
WARRANTY AND LIMITATION OF LIABILITY.....	29
START-UP REPORT FORM	30
NOTES	33

INTRODUCTION

This Installation, Operation and Maintenance manual provides important information on safety and the proper inspection, disassembly, reassembly and testing of the BJM Pumps® KZNMD Series submersible pump. This manual also contains information to optimize performance and longevity of your **BJM Pumps®** submersible pump.

The submersible KZNMD Series pumps are designed to pump water and water based slurries. The KZNMD Series pumps are not explosion-proof. They are not designed to pump volatile or flammable liquids.

Note: Consult chemical resistance chart for compatibility between pump materials and liquid before operating pump.

If you have any questions regarding the inspection, disassembly, assembly or testing please contact your **BJM Pumps** distributor, or Industrial Flow Solutions Operating, LLC.

Industrial Flow Solutions Operating, LLC
104 John W Murphy Drive
New Haven, CT 06513, USA

Phone: 860-631-3618

Information, including pump data sheets and performance curves, is also available on our web site: www.flowsolutions.com

For assistance with your electric power source, please contact a certified electrician.

Please pay attention to the following alert notifications. They are used to notify operators and maintenance personnel to pay special attention to procedures, to avoid causing damage to the equipment, and to avoid situations that could be dangerous to personnel.

NOTE: Instructions to aid in installation, operation, and maintenance or which clarify a procedure.

⚠ DANGER Immediate hazards that WILL result in severe personal injury or death. These instructions describe the procedure required and the injury which will result from failure to follow the procedure.

⚠ WARNING Hazards or unsafe practices that COULD result in severe personal injury or death. These instructions describe the procedure required, and the injury which could result from failure to follow the procedure.

⚠ CAUTION Hazards or unsafe practices which COULD result in personal injury or product or property damage. These instructions describe the procedure required and the possible damage which could result from failure to follow the procedure.

SAFETY

Pump installations are seldom identical. Each installation and application can vary due to many different factors. It is the owner/service mechanics responsibility to repair, service, and test to ensure that the pump integrity is not compromised according to this manual.

⚠ WARNING Risk of electric shock – this pump has not been investigated for use in swimming pool areas.

⚠ DANGER Do not pump flammable, inflammable or volatile liquids. **Death or serious injury will result.**

⚠ WARNING Before attempting to open or service the pump:

- 1) Familiarize yourself with this manual.
- 2) Unplug or disconnect the pump power cable to ensure that the pump will remain inoperative.
- 3) Allow the pump to cool if overheated.

⚠ WARNING Do not operate the pump with a worn or damaged electric power cable. Death or serious injury could occur.

⚠ WARNING Never attempt to alter the length or repair any power cable with a splice. The pump motor and pump motor and cable must be completely waterproof. Damage to the pump or personal injury may result from alterations.

⚠ WARNING After the pump has been installed, make sure that the pump and all piping are secure before operation.

⚠ WARNING Do not lift the pump by the power cable piping or discharge hose. Attach proper lifting equipment to the lifting handle (or lifting rings) fitted to the pump. Do not suspend the pump by the power cable.

⚠ WARNING Obtain the services of a qualified electrician to troubleshoot, test and/or service the electrical components of this pump.

⚠ CAUTION Pumps and related equipment must be installed and operated according to all national, local and industry standards.



INSPECTION

Review all safety information before servicing pump.

The following are recommended installation practices/procedures for the pump. If there are questions in regard to your specific application, contact your local **BJM Pumps®** distributor or Industrial Flow Solutions Operating, LLC.

PRE-INSTALLATION INSPECTION

- 1) Check the pump for damage that may have occurred during shipment.
- 2) Inspect the pump for any cracks, dents, damaged threads, etc.
- 3) Check power cord (and seal minder cord, if installed) for any cuts or damage.
- 4) Check for, and tighten any hardware that appears loose.
- 5) Carefully read all tags, decals and markings on the pump.
- 6) **Important:** Always verify that the pump nameplate, amps, voltage, phase, and HP ratings match your control panel and power supply.

Warranty does not cover damage caused by connecting pumps and controls to an incorrect power source (voltage/phase supply). Record the model numbers and serial numbers from the pumps and control panel on the front of this instruction manual for future reference. Give it to the owner or affix it to the control panel when finished with the installation.

If anything appears to be abnormal, contact your **BJM Pumps®** distributor or Industrial Flow Solutions Operating, LLC. If damaged, the pump may need to be repaired before use. Do not install or use the pump until appropriate action has been taken.

Lubrication:

No additional lubrication is necessary. The shaft seal and bearings are fully lubricated from the factory. Seal oil should be checked one per year. See table below.

OIL FILL QUANTITY/TYPE

Models	Qty. oil in seal chamber		
	U.S. fl. oz.	C.C.	Type of oil
KZNMD 37, 55, 55CH, 75	49	1450	ISO 32 NSF Food Grade Mineral Oil
KZNMD 110, 110H, 150, 150L	125	3700	ISO 32 NSF Food Grade Mineral Oil
KZNMD 220, 220L	213	6300	ISO 32 NSF Food Grade Mineral Oil

PUMP INSTALLATION

KZNMD Series pumps have been evaluated for use with water or water based solutions. Please contact the manufacturer for additional information.

WARNING

Risk of electric shock. KZNMD Series pump models do not come with electric plug connectors. To reduce the risk of electric shock, be certain that it is connected only to a properly grounded, grounding-type receptacle or control panels.

Lifting:

Attach a rope or lifting chain (not included) to the handle (or lifting rings) on the top of the pump.

CAUTION

Do not lift the pump by the power cable or discharge hose/piping. Proper lifting equipment (rope/chain) must be used.

POSITIONING THE PUMP

BJM Pumps® KZNMD Series pumps are designed to operate fully or partially submerged. Do not run the pump dry. Refer to data sheet for minimum submersion depth for your particular model. Data sheets can be obtained online at www.flowsolutions.com or by calling Industrial Flow Solutions Operating, LLC at 860-631-3618. As a general rule, KZNMD Series top discharge pumps can pump down to a level above the suction screen. Pumping lower than screen will permit air to enter the pump and cavitate, lose prime or become air bound.

CAUTION

- Do not run pump dry.
- Pump liquid should not exceed a maximum temperature of 104°F.
- Never place the pump on loose or soft ground. The pump may sink, preventing water from reaching the impeller. Place on a solid surface or suspend the pump with a lifting rope/chain. The KZNMD Series pumps are provided with a suction strainer to prevent large solids from clogging the impeller. Any spherical solids which pass through the strainer should pass through the pump.
- For maximum pumping capacity, use the proper size non-collapsible hose or rigid piping. A check valve may be installed after the discharge to prevent back flow when the pump is shut off.

PUMP ROTATION

Two ways to check the correct pump rotation:

1. By looking at the impeller; the rotation of the impeller should be counter clockwise as shown in the picture below.

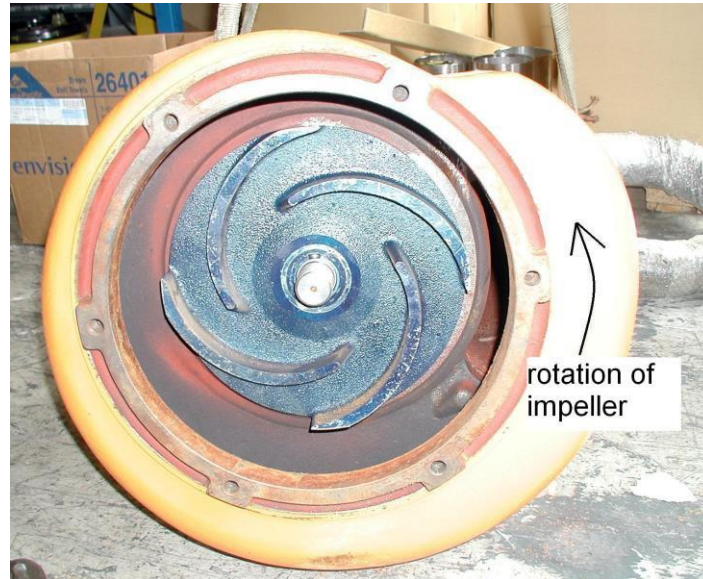

2. By looking from the top of the pump. Since the impeller cannot be seen, the best way to check the rotation is to check the kick back motion of the pump when the pump just starts. The kick back motion of the pump should be counter clockwise as shown in the picture below.



PUMP OPERATION

⚠ WARNING

This pump is designed to handle dirty water that contains some solids. It is not designed to pump volatile or flammable liquids. Do not attempt to pump any liquids which may damage the pump or endanger personnel as a result of pump failure.

⚠ DANGER

Do not operate this pump where explosive vapors or flammable material exist. Death or Serious injury will result.

TYPICAL MANUAL DEWATERING INSTALLATION

NOTE: Maximum recommended starts should not exceed 10 times per hour.

All KZNMD models are provided with a 50' (10m) power cord. NEVER splice the power cable due to safety and warranty considerations. Always keep the plug end dry.

Note: 208V, 230V, 460V & 575V three phase units do not have a plug and have to be provided separately.

⚠ WARNING

Do not alter the length or repair any power cable with a splice. The pump motor and cable must be completely waterproof. Damage to the pump or personal injury may result from alterations.

For manual operation: 208, 230, 460 & 575 volt: Attach the proper plug or connect directly to the power source or control box. KZNMD model pumps are supplied with two grounding wires; one green for grounding to the panel; the other is orange and is to be used for grounding check systems or can be also connected to the grounding point on the control. Check the direction of the rotation. Tilt the pump and start it. It should twist in the opposite direction of the arrow (on pump). It is recommended that a Ground Fault Interrupter (GFI) type receptacle (or equivalent) be used.

STOPPING

To stop the pump (manual and automatic mode), unplug it from the power source, turn off the breaker, or turn the power source off (generator).

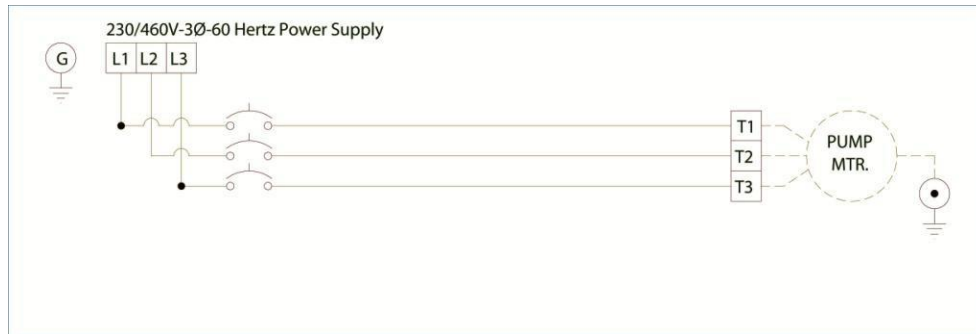

Typical 3 phase manual control 1

TYPICAL AUTOMATIC DEWATERING INSTALLATION

NOTE: Maximum recommended starts should not exceed 10 times per hour.

Note: 208V, 230V, 460V & 575V pumps do not have a plug installed.

Three phase pumps need a separate control box with float(s) for automatic operation. Control box not included with pump.

TYPICAL SIMPLEX INSTALLATION WITH CONTROL PANEL AND 3 FLOATS

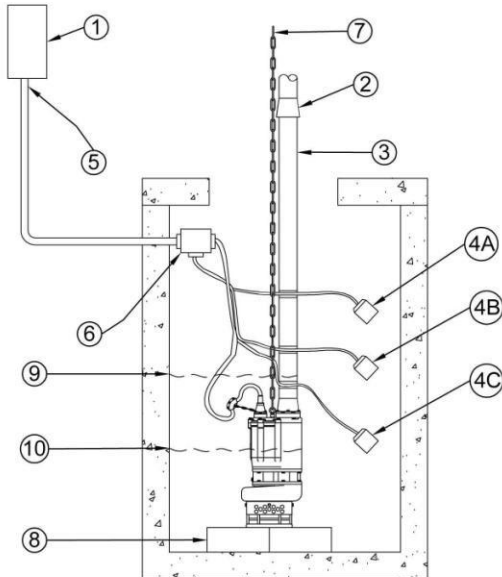

- 1)** Electrical wiring and protection must be in accordance with National Electrical Code in U.S.A. or Canadian Electrical Code in Canada and state / provincial and local electrical codes.
- 2)** Optional (approx. 50' / 15 meters) : If pumping in a small confined space at high head, it may be beneficial to install a check valve 3' (1 meter) above the discharge of the pump. This will help eliminate backflow and unnecessary running of the pump. For best results use a section of PVC.
- 3)** PVC pipe or rigid hose recommended. Collapsible vinyl hose will work but not as efficiently.
- 4)** Attach float to the pump top or PVC pipe. Never place the float lower than the top of the strainer inlet.
 - 4A** - alarm float.
 - 4B** - turn on.
 - 4C** - turn off.
- 5)** All electrical connections must be kept dry.
- 6)** Wire pump and floats to control panel through a watertight junction box.
- 7)** Always lower the pump by a separate chain. Never lift or lower the pump by the power cord, piggy-back cord or discharge hose.
- 8)** For best results, place the pump on a solid object. This will keep the pump from digging itself into silt, sand and mud.
- 9)** Recommended submergence level.
- 10)** Minimum submergence level.

STOPPING

To stop the pump (manual and automatic mode), unplug it from the power source, turn off the breaker, or turn the power source off (generator).

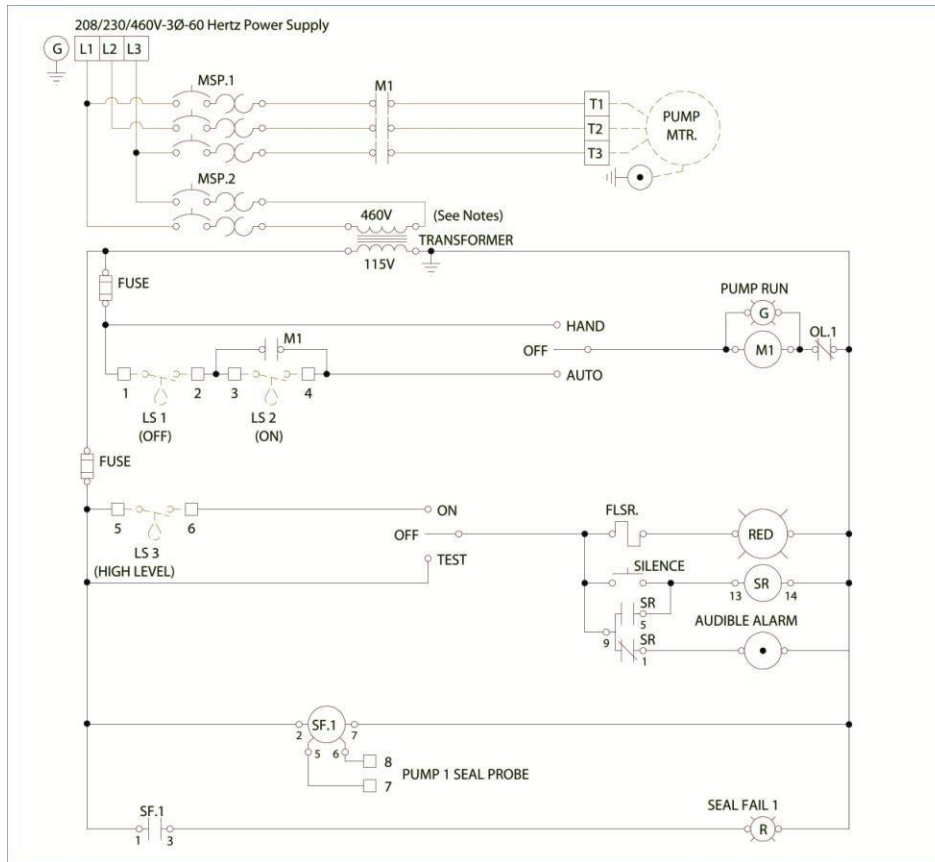

Typical 3 phase Auto Control 1

INTENDED METHODS OF CONNECTION

⚠ CAUTION Use with approved motor control that matches motor input in full load amperes. “UTILISER UN DÉMARREUR APPROUVÉ CONVENANT AU COURANT À PLEINE CHARGE DU MOTEUR.”

BJM Pumps submersible pumps have been evaluated for use with water or water based solutions. Please contact the manufacturer for additional information.

THREE PHASE WIRING INSTRUCTION

⚠ WARNING **FOR YOUR PROTECTION, ALWAYS DISCONNECT PUMP FROM ITS POWER SOURCE BEFORE HANDLING.**

⚠ WARNING “Risk of electrical shock” Do not remove power supply cord and strain relief or connect conduit directly to the pump.



⚠ WARNING

Installation and checking of electrical circuits and hardware should be performed by a qualified licensed electrician.

To automatically operate a non-automatic three phase pump, a control panel is required. Follow the instructions provided with the panel to wire the system. For automatic three phase pumps see automatic three phase wiring diagram.

Before installing a pump, check the pump rotation to insure that wiring has been connected properly to power source, and that the green lead of power cord (See wiring diagram), is connected to a valid ground, momentarily energize the pump, observing the directions of kick back due to starting torque. Rotation is correct if kick back is in the opposite direction of rotation arrow on the pump casing. If rotation is not correct, switching of any two power leads other than ground will provide the proper rotation.

Three phase pumps have integral motor overload protection. It is recommended that all three phase pumps using a motor starting device also incorporate motor overload protection. Pumps **must** be installed in accordance with the National Electrical Code and all applicable local codes and ordinances. Pumps are not to be installed in locations classified as hazardous in accordance with National Electrical Code, ANSI/NFPA 70.

Connect pump to a junction box, outlet box, control box, enclosure with a wiring compartment that meets NEC and local codes. The provision for supply connection shall reduce the risk of water entry during temporary, limited submersion and shall comply with the applicable requirements of the Standard for Enclosures for Electrical Equipment, UL 50, or the standard for Metallic Outlet Boxes, UL 514A, and the standard for Motor-Operated Water Pumps. UL 778.

TROUBLE SHOOTING



Disconnect the power source to the pump BEFORE attempting any type of trouble shooting, service or repair.

PUMP WILL NOT RUN

1. Check power supply (fuses, breaker). Reset power.
2. Blocked impeller. Remove strainer, check and clean.
3. Defective cable or incorrect wiring.
4. Strainer clogged. Check and clean as necessary.
5. Float switch tangled/obstructed. Clean and free float switch from obstruction.
6. Float switch defective. Replace float switch.
7. Pump overheated or temperature of liquid exceeds pump operating temperature.

Warning: Pump will restart automatically when motor over-heat protection switch cools.

PUMP RUNS BUT DOES NOT DELIVER RATED CAPACITY

1. Discharge line clogged, restricted or hose kinked. Check discharge hose/pipe.
2. Worn impeller and/or suction cover. Inspect and replace as necessary.
3. Pump overloaded due to liquid pumped being too thick.
4. Pumping air. Check liquid level and position of pump.
5. Excessive voltage drops due to long cables.
6. Three phase only; pump running backwards, check rotation.

SERVICING YOUR SUBMERSIBLE PUMP

Pump should be disconnected from the electric power supply before proceeding to do any service or maintenance.

To service or repair your pump, please contact your local **BJM Pumps®** distributor. Service should only be performed by a qualified electrician.

MAINTAINING YOUR PUMP

- Pump should be disconnected from the electric power supply before proceeding to do any service or maintenance.
- Pump should be inspected at regular intervals.



- More frequent inspections are required if the pump is used in a harsh environment.
- Preventative maintenance should be performed to reduce the chance of premature failure.
- Worn impellers and lip seals should be replaced.
- Cut or cracked power cords must be replaced. **(Never operate a pump with a cut, cracked or damaged power cord.)**
- Seal oil should be checked once per year.
- Maintenance should always be done when taking a pump out of service before storage.
 - 1) Clean pump of dirt and other build up.
 - 2) Check condition of oil around the shaft seals.
 - 3) Check hydraulic parts: check for wear.
 - 4) Inspect power cable. Make sure that it is free of nicks or cuts.

CHANGING SEAL OIL

Changing the seal oil in the KZNMD Series pumps is very easy.

- 1) Make sure that the pump cable is disconnected from the power source.
- 2) Lay the pump down on its side.
- 3) Remove the screws that hold the bottom plate in place.
- 4) Remove bottom plate.
- 5) Remove screws holding the suction cover.
- 6) Remove the suction cover.
- 7) Remove the impeller.
- 8) Remove the inspection screw for the oil chamber (pos#50-08). Pour out a small sample of the oil. If it is milky white, or contains water, then the oil and possible, the mechanical seal, should be changed. If an oil change is needed:
- 9) Remove the screws that hold the oil chamber cover in place & remove the oil.
- 10) Replace the mechanical seal if necessary.
- 11) Replace the oil.
- 12) Assemble the pump.

CHANGING SEALS*

- 1) Make sure that the pump cable is disconnected from the power source.
- 2) Lay the pump down on its side.
- 3) Remove the oil inspection bolt (pos#50-11) from the oil seal chamber.
- 4) Drain out all the inside the oil seal chamber.
- 5) Remove the bolts holding the stand.
- 6) Remove the stand.
- 7) Remove the bolts holding the suction cover.
- 8) Remove the suction cover.
- 9) Remove the agitator.
- 10) Remove the impeller, impeller key and shims.
- 11) Remove the bolts holding the pump housing.
- 12) Remove the pump housing.
- 13) Remove the shaft sleeve. Note the shaft sleeve direction.
- 14) Remove the bolts holding the oil cover.
- 15) Remove the oil cover.
- 16) Remove the screws holding the seal retainer.
- 17) Remove the seal retainer.
- 18) Remove the mechanical seal.
- 19) Replace the mechanical seal, lip seal and o-rings.
- 20) Assemble the pump.
- 21) Fill with recommended new oil.
- 22) Replace the oil inspection bolt o-ring.
- 23) Secure the oil inspection bolt.

*Note: If there is excessive liquid found in the oil or mechanical seal damaged, please contact **BJM Pumps®** authorized service centers



Appendices:

Technical Data:

KZN37MD	DS-C69-001
KZN55MD	DS-C69-002
KZN75MD	DS-C69-004

Specifications:

KZNMD Series	DS-C69-022
--------------	------------

THREE PHASE WIRING DIAGRAMS

230V (5 LEAD)

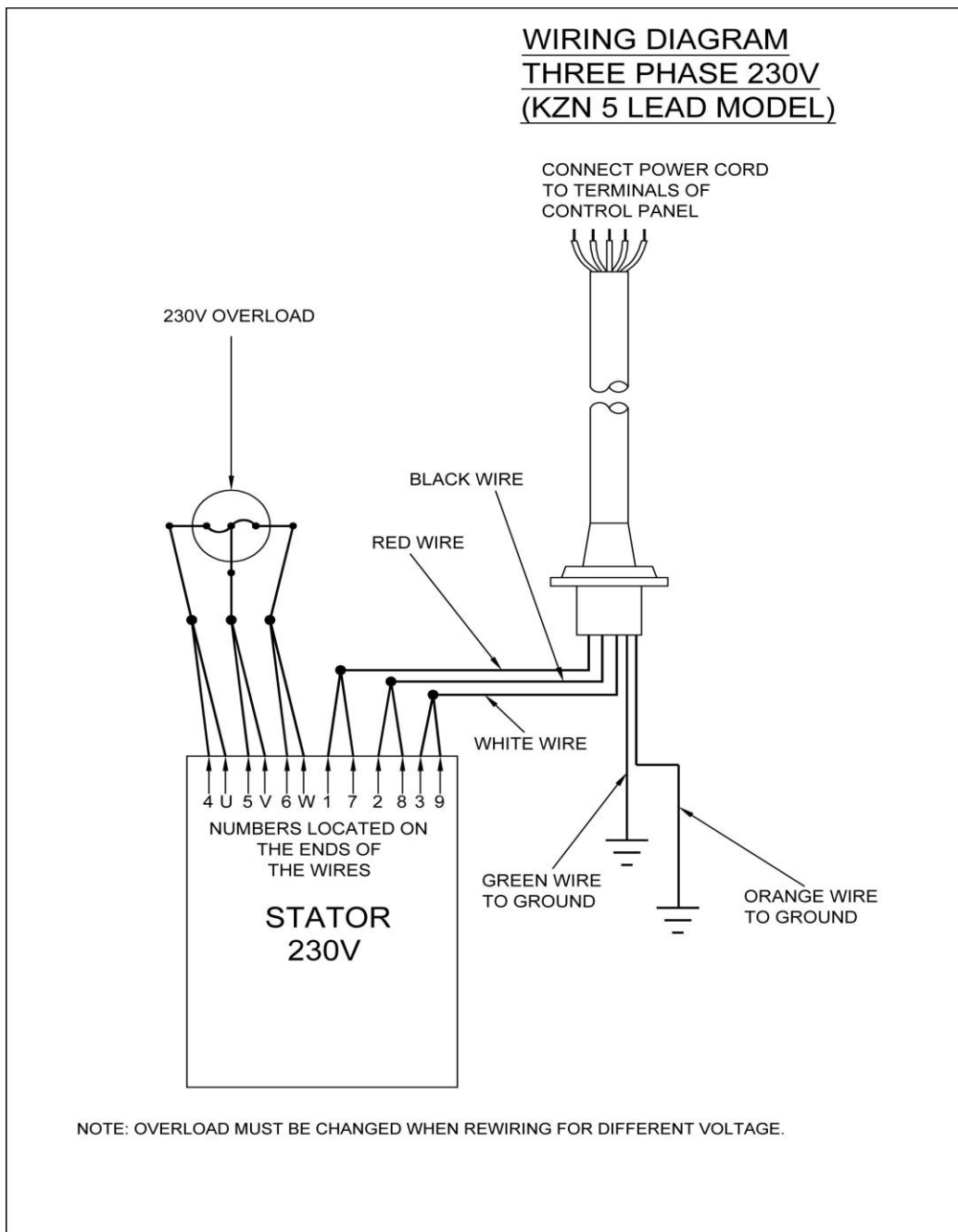

MODELS KZN 37, 37R, 55, 55CH, 55R, 55CHR, 75, 75R, 110, 110H, 110R, 110HR

460V (5 LEAD)

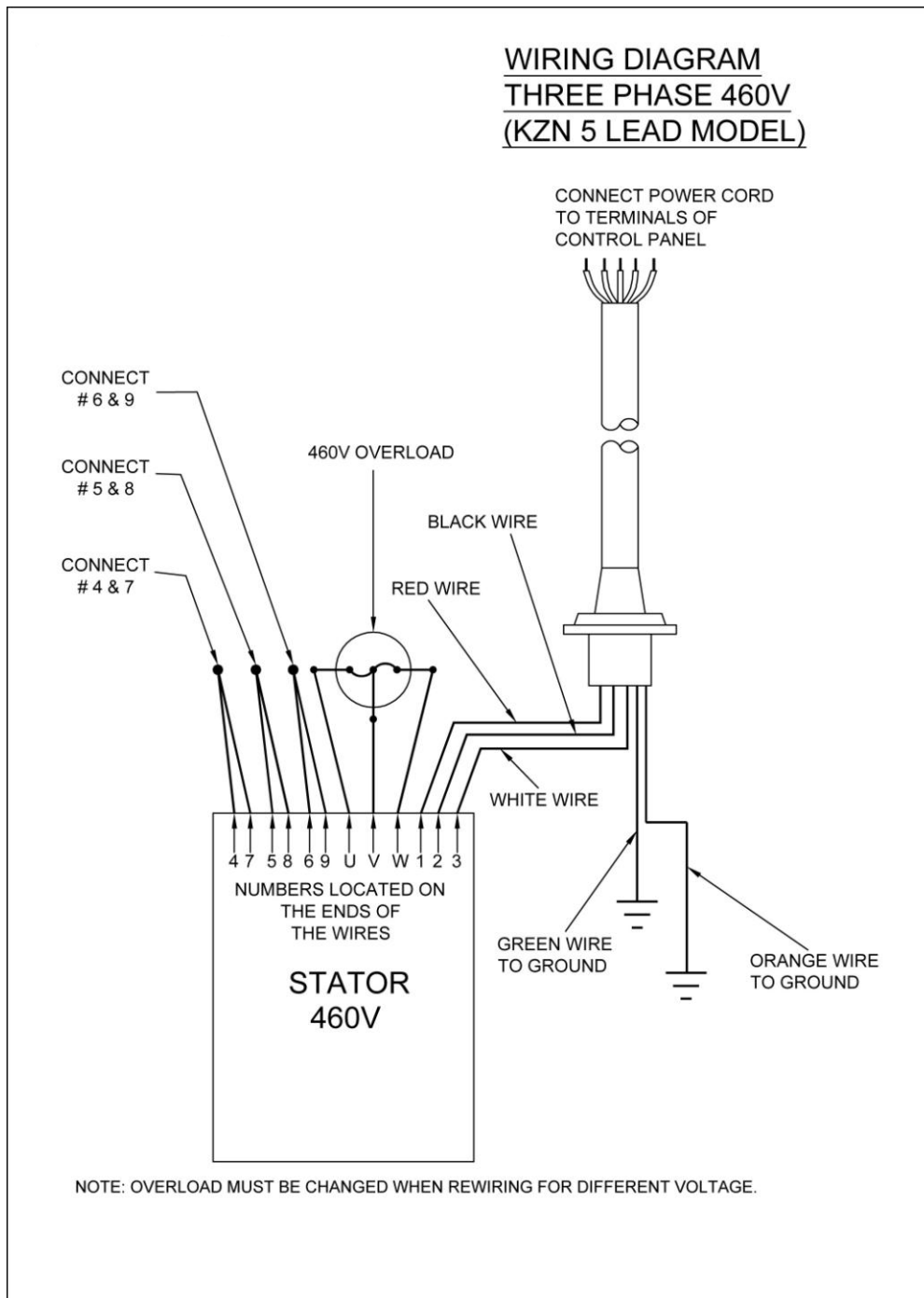

MODELS KZN 37, 37R, 55, 55R, 55CHR, 75, 75R, 110, 110H, 110HR, 150, 150L, 150R, 150LR, 150R, 220, 220L, 220LR, 220R

575V (5 LEAD)

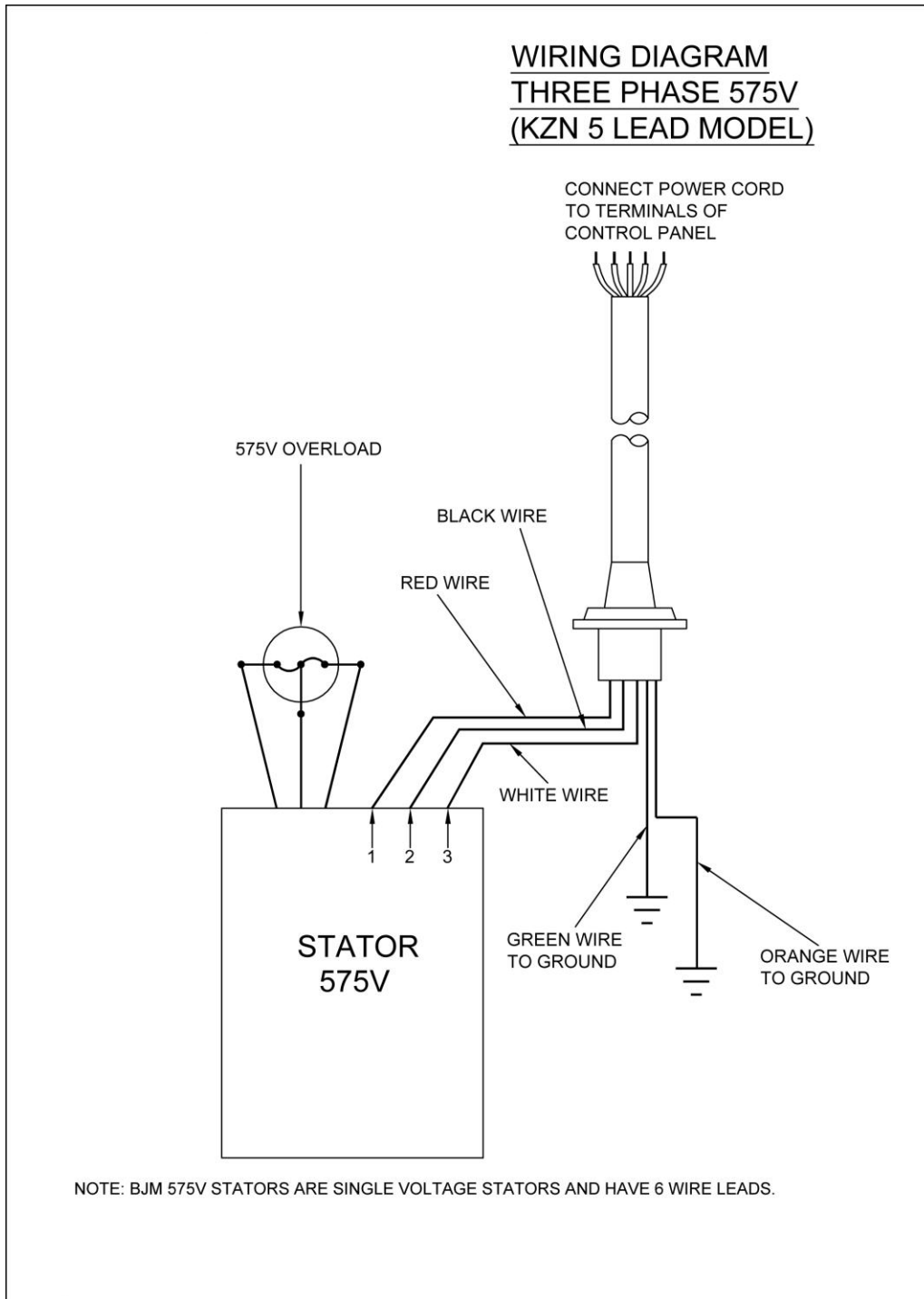

MODELS KZN 37, 37R, 55, 55R, 55CHR, 75, 75R, 110, 110H, 110HR, 150,
150L, 150L, 150LR, 150R, 220, 220L, 220LR, 220R

SEAL MINDER® Information

Seal Minder®:

Also known as a seal fail circuitry (or moisture detection circuit) is designed to inform the pump operator that there is moisture within the oil chamber. This early warning can allow the operator to schedule repair & inspection on the pump. The **Seal Minder®** is a sensor probe inside the oil chamber. (The oil chamber houses the mechanical seals that are cooled & lubricated by oil). The **Seal Minder**, when properly connect to a control panel, can help indicate seal failure. The **Seal Minder** cord requires a seal fail circuitry in control panel for warning signal.

The open end of the **Seal Minder** circuit cord should be connected to a control panel with an optional seal failure alarm relay circuit or a standalone **Seal Minder** Panel manufactures can incorporate the Seal Minder cord option. BJM Pumps®, an Industrial Flow Solutions Company, has a standalone, **Seal Minder** panel for both simplex (P/N MSP8350A) and duplex (P/N MSP8350B) systems. For more information, contact Industrial Flow Solutions Operating, LLC or visit us online at www.flowsolutions.com

The **Seal Minder** cord has two leads, black and white. Note that the power cable is much larger and has three to five leads, depending on the model. Inside the pump, the black lead is connected to the casing ground, and the white lead is connected to the seal probe that is suspended into the oil chamber. These leads need to be properly connected to the seal failure alarm relay circuit. Most controls that have proceeded this option have a connection terminal point that is clearly marked for these connections. Consult the control panel manual for proper connection instructions.

Although highly recommended, the pump does not need a control box with seal fail relay or standalone seal panel to operate.

If the operator does not use the **Seal Minder**:

- 1.) The recommended procedure is to take the **Seal Minder** cord off the pump and seal with a **Seal Minder** cap (P/N M02738) and gasket (P/N M05121 for Buna, P/N M05121V for FKM). This should be done by an authorized BJM Pumps® service center or distributor as not to void warranty (detailed instruction sheet available for this procedure).
- 2.) Alternate method of securing **Seal Minder** cable if not being used: Tape the **Seal Minder** cord to the power cord. Make sure that the cords are taped together in an even run, at about 2' to 3' apart. Use electrical tape to tape off the end of the **Seal Minder** cable (do not connect to power source). The taped leads should be kept dry and out of the liquid. (See next page for detailed drawing).

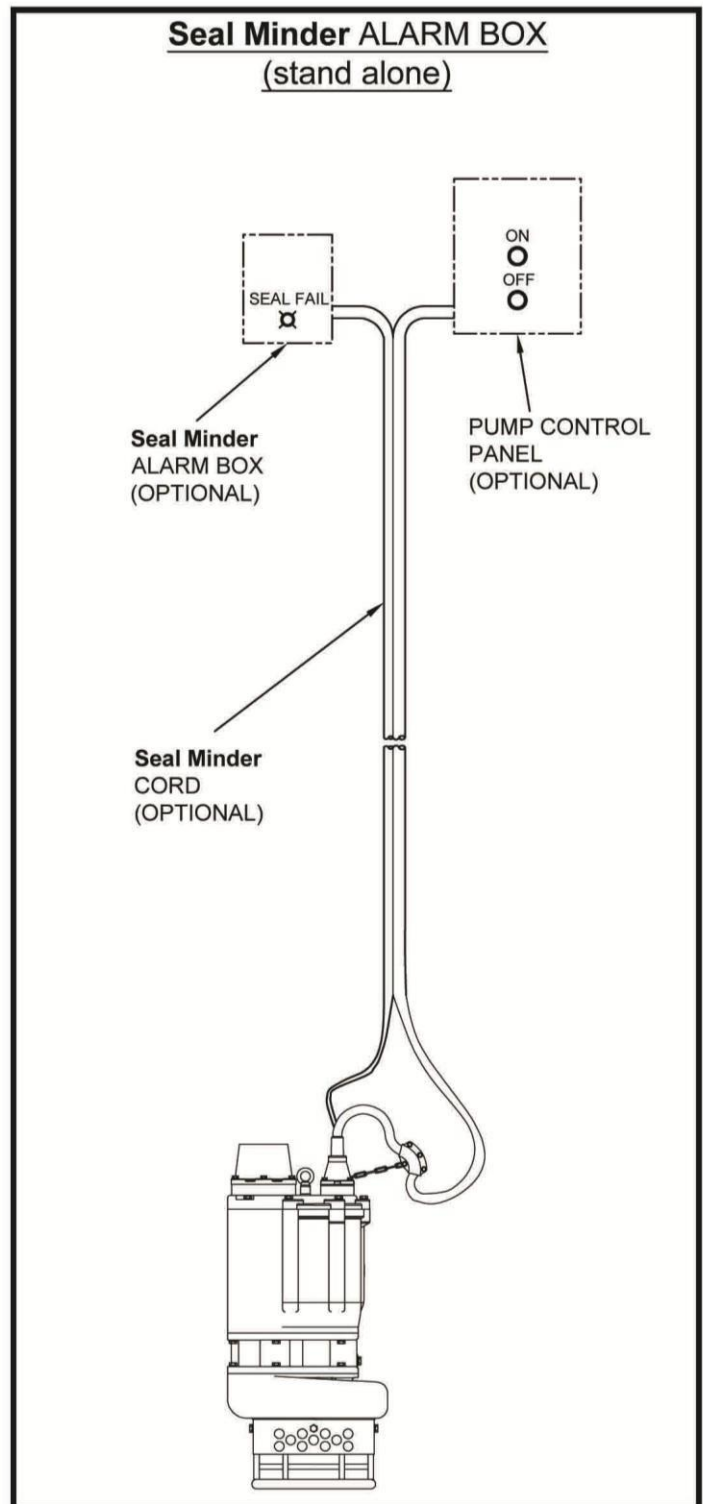
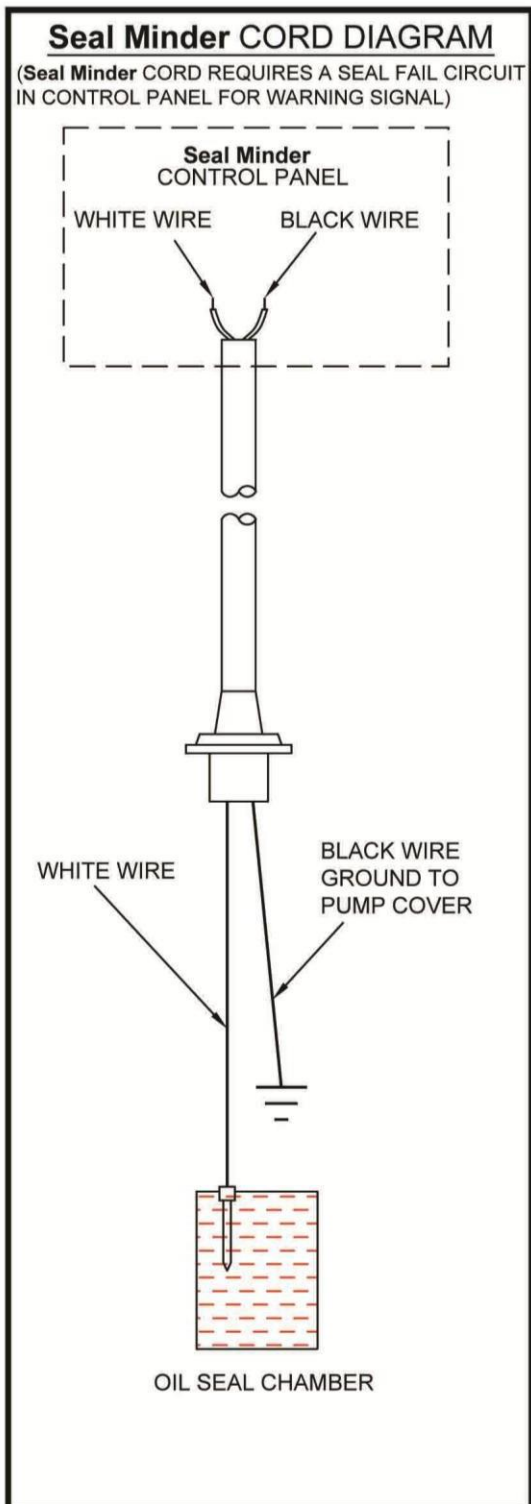

SPECIFICATIONS SUBJECT TO CHANGE WITHOUT NOTICE.



Industrial Flow Solutions Operating, LLC
104 John W Murphy Drive
New Haven, CT 06513, USA

WARRANTY AND LIMITATION OF LIABILITY

Unless otherwise expressly authorized in writing, specifying a longer or shorter period, BJM Pumps, LLC warrants for a period of eighteen (18) months from the date of shipment from the Point of Shipment, or one (1) year from the date of installation, whichever occurs first, that all products or parts thereof furnished by BJM Pumps, LLC under the brand name **BJM Pumps**, hereinafter referred to as the "Product" are free from defects in materials and workmanship and conform to the applicable specification.

BJM Pumps, LLC's liability for any breach of this warranty shall be limited solely to replacement or repair, at the sole option of BJM Pumps, LLC, of any part or parts of the Product found to be defective during the warranty period, provided the Product is properly installed and is being used as originally intended. Any breach of this warranty must be reported to BJM Pumps, LLC or BJM Pumps, LLC's authorized service representative within the aforementioned warranty period, and defective Product or parts thereof must be shipped to BJM Pumps, LLC or BJM Pumps, LLC's authorized representative, transportation charges prepaid. Any cost associated with removal or installation of a defective Product or part is excluded.

IT IS EXPRESSLY AGREED THAT THIS SHALL BE THE SOLE AND EXCLUSIVE REMEDY OF BJM PUMPS, LLC'S DISTRIBUTORS AND CUSTOMERS. UNDER NO CIRCUMSTANCES SHALL BJM PUMPS, LLC BE LIABLE FOR ANY COSTS, LOSS, EXPENSE, DAMAGES, SPECIAL DAMAGES, INCIDENTAL DAMAGES OR CONSEQUENTIAL DAMAGES ARISING DIRECTLY OR INDIRECTLY FROM THE DESIGN, MANUFACTURE, SALE, USE OR REPAIR OF THE PRODUCT, WHETHER BASED ON WARRANTY, CONTRACT, NEGLIGENCE, OR STRICT LIABILITY. IN NO EVENT WILL LIABILITY EXCEED THE PURCHASE PRICE OF THE PRODUCT.

THE WARRANTY AND LIMITS OF LIABILITY CONTAINED HEREIN ARE IN LIEU OF ALL OTHER WARRANTIES AND LIABILITIES, EXPRESSED OR IMPLIED. ALL IMPLIED WARRANTIES OF MERCHANTABILITY AND FITNESS FOR A PARTICULAR PURPOSE ARE HEREBY DISCLAIMED BY BJM PUMPS, LLC AND EXCLUDED FROM THIS WARRANTY.

BJM Pumps, LLC neither assumes, nor authorizes any person to assume for it, any other warranty obligation in connection with the sale of the Product. This warranty shall not apply to any Product or parts of Product which have (a) been repaired or altered outside of BJM Pumps, LLC's facilities unless such repair was authorized in advance by BJM Pumps, LLC or by its authorized representative; or (b) have been subject to misuse, negligence or accident; or (c) have been used in a manner contrary to BJM Pumps, LLC's instruction.

In any case of products not manufactured and sold under the BJM Pumps, LLC brand name, there is no warranty from BJM Pumps, LLC; however BJM Pumps, LLC will extend any warranty received from BJM Pumps, LLC's supplier of such products.

START-UP REPORT FORM

START-UP REPORT FORM

This form is designed to record the initial installation, and to serve as a guide for troubleshooting at a later date (if needed).

Industrial Flow Solutions Operating, LLC
 104 John W Murphy Drive
 New Haven, CT 06513, USA

Pump Owner's Name			
Location of Installation			
Person in Charge		Phone()	
Purchased From			
Model		Serial No	
Voltage	Phase	Hertz	HP
Does impeller turn freely by hand?	<input type="checkbox"/> Yes <input type="checkbox"/> No		
Condition of Equipment	<input type="checkbox"/> New <input type="checkbox"/> Good <input type="checkbox"/> Fair <input type="checkbox"/> Poor		
Condition of Cable Jacket	<input type="checkbox"/> New <input type="checkbox"/> Good <input type="checkbox"/> Fair <input type="checkbox"/> Poor		
Rotation: Direction of Impeller Rotation (Use C/W for clockwise, CC/W for counterclockwise): _____ Method used to check rotation (viewed from bottom) _____			
Resistance of cable and Pump Motor (measured at pump control)			
Red-Black _____ ohms	Red-White _____ ohms	White-Black _____ ohms	
Resistance of ground circuit between control panel and outside of pumps _____ Ohms			
MEG OHM CHECK OF INSULATION			
Red to ground _____ White to ground _____ Black to ground _____			
Condition of location at start-up	<input type="checkbox"/> Dry <input type="checkbox"/> Wet <input type="checkbox"/> Muddy		
Was equipment stored If YES, length of storage:	<input type="checkbox"/> Yes <input type="checkbox"/> No.		
Liquid being pump			
Debris in bottom of station?	<input type="checkbox"/> Yes <input type="checkbox"/> No		
Was debris removed in your	<input type="checkbox"/> Yes <input type="checkbox"/> No		

START-UP REPORT FORM

presence?		
Are guide rails exactly vertical?	<input type="checkbox"/> Yes	<input type="checkbox"/> No
Is base elbow installed level?	<input type="checkbox"/> Yes	<input type="checkbox"/> No
Liquid level controls: Model _____		
Is control installed away from turbulence?	<input type="checkbox"/> Yes	<input type="checkbox"/> No
Operation Check		
Tip lowest float (stop float), all pumps should remain off. Tip second float (and stop float), one pump comes on. Tip third float (and stop float), both pumps on (alarm on simplex). Tip fourth float (and stop float), high level alarm on (omit on simplex).		
If not on levels controls, describe type of controls		
Does liquid level ever drop below volute top?	<input type="checkbox"/> Yes	<input type="checkbox"/> No
Control Panel MFG & model no.		
Number of pumps operated by control panel		
NOTE: At no time should hole be made in top of control panel, unless proper sealing devices are utilized.		
Short Circuit protection:	Type:	
Number and size of short circuit device(s)	Amp rating:	
Overload type:	Size:	Amp rating:
Do protective devices comply with pump motor amp rating?	<input type="checkbox"/> Yes	<input type="checkbox"/> No
Are all pump connections tight?	<input type="checkbox"/> Yes	<input type="checkbox"/> No
Is the interior of the panel dry?	<input type="checkbox"/> Yes	<input type="checkbox"/> No If No, correct moisture problem.
Electrical readings		
SINGLE PHASE		
Voltage supply at panel line connection, pump off	L1	L2
Voltage supply at panel line connection, pump on	L1	L2
Amperage load connection, pump on	L1	L2
THREE PHASE		
Voltage supply at panel line connection, pump off		
L1-L2	L2-L3	L3-L1

START-UP REPORT FORM

Voltage supply at panel line connection, pump on		
L1-L2	L2-L3	L3-L1
Amperage load connection, pump on		
L1	L2	L3
FINAL CHECK		
Is pump secured properly?	<input type="checkbox"/> Yes <input type="checkbox"/> No	
Was pump checked for leaks?	<input type="checkbox"/> Yes <input type="checkbox"/> No	
Do check valves operate properly?	<input type="checkbox"/> Yes <input type="checkbox"/> No	
Flow: Does station appear to operate at proper rate?	<input type="checkbox"/> Yes <input type="checkbox"/> No	
Noise level:	Acceptable <input type="checkbox"/>	Unacceptable <input type="checkbox"/>
Comments:		
Describe and equipment difficulties during start-up		
Installed by: Company: _____ Person: _____ Date: _____		
Maintained by: Company: _____ Person: _____		
Date and time of start-up _____ Present at start-up: () Engineer's name _____ () Contractor's name _____ () Operator's name _____ () others _____		

Industrial Flow Solutions Operating, LLC
104 John W Murphy Drive, New Haven, CT 06513, USA
Phone: (860) 399-5937 • Fax: (860) 399-7784
Email: sales@flowsolutions.com • Web Site: www.flowsolutions.com